

FULL DEPTH PAVEMENT REPAIR DETAIL

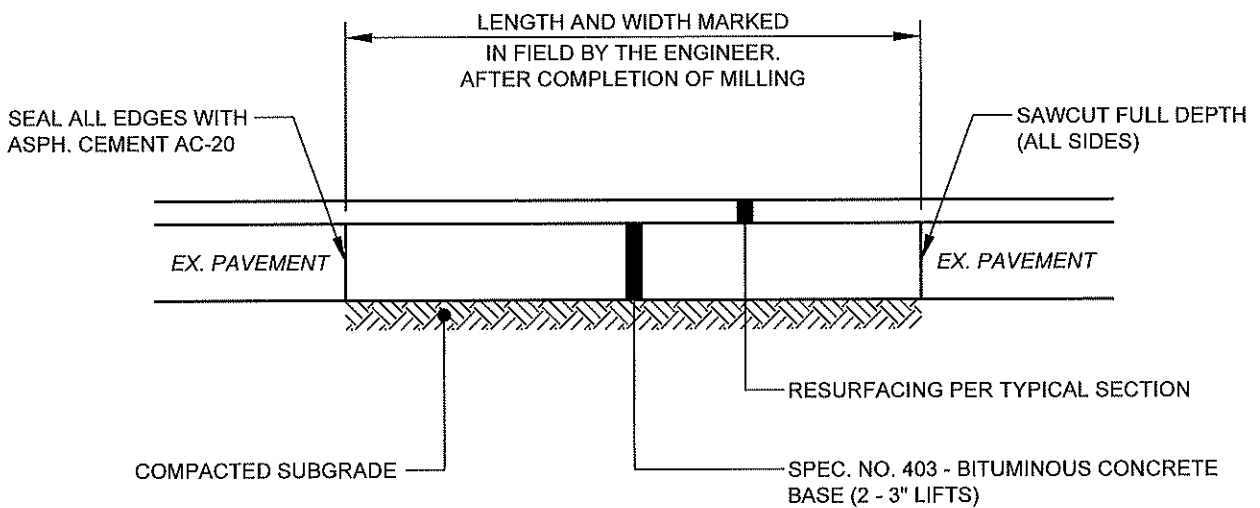

NOTE:

Contractor shall be prepared to perform full depth pavement repair within 24 hours of surface milling. The City and the Engineer to review condition of pavement surface after pavement milling to determine areas, if necessary, of full depth repair. It shall be the Contractor's responsibility to repair full depth pavement areas within 48 hours of pavement milling.



your trusted advisor
consultants

→ engineers
architects
planners



TYPICAL SECTION FAIRVIEW PLACE

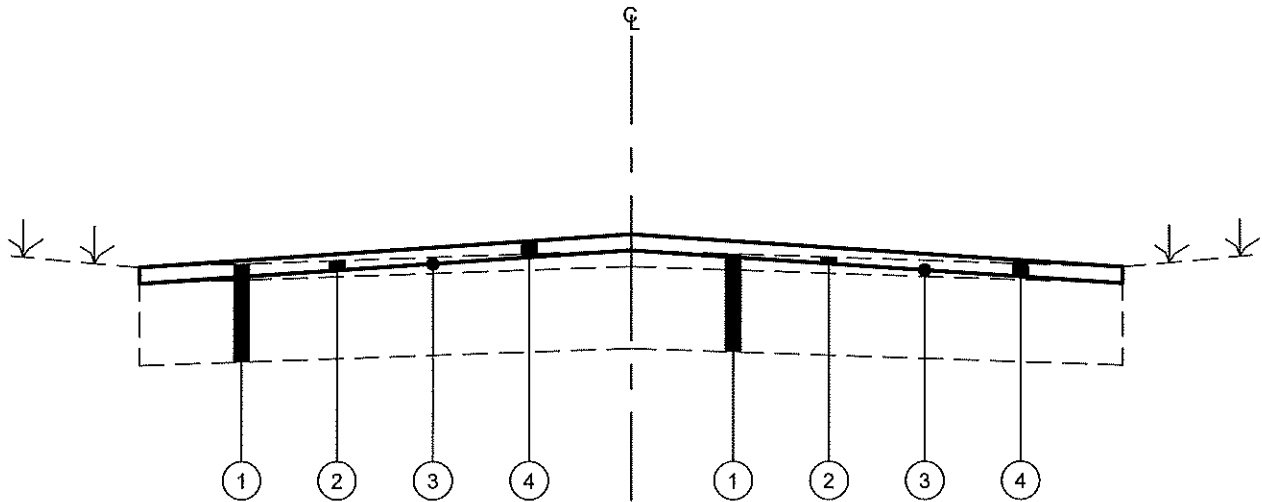

LEGEND

- ① EXISTING ASPHALT
- ② SPEC. NO. 408 - ASPHALT PAVEMENT MILLING, VARIABLE DEPTH, 1.5" AT GUTTER / E/P TO 0" AT CENTERLINE
- ③ SPEC. NO. 406 - TACK COAT INCIDENTAL TO ④
- ④ ITEM 402/403 - 1.5" ASPHALT PAVEMENT SURFACE WITH FIBER REINFORCEMENT

NOTE:

- 1.) APPLY HOT POURED JOINT SEALER AT CONSTRUCTION JOINTS AT BEGINNING AND END OF PROJECT LIMITS, INCIDENTAL TO ④
- 2.) A CONTINGENCY QUANTITY OF 402 / 403 ASPHALT PAVEMENT LEVELING COURSE IS INCLUDED IN THE CONTRACT. AFTER MILLING THE OWNER WILL REVIEW THE CONDITION OF THE SUBGRADE TO DETERMINE IF A LEVELING COURSE IS NEEDED. LEVELING COURSE MAY BE APPLIED AT THE SOUTHWEST EDGE OF PAVEMENT TO ADJUST THE DRAINAGE AREA TO THE EXISTING CATCH BASIN.



TYPICAL SECTION

GRANT STREET OHIO AVENUE RIDGEWAY AVENUE SHERIDAN AVENUE SHERMAN AVENUE

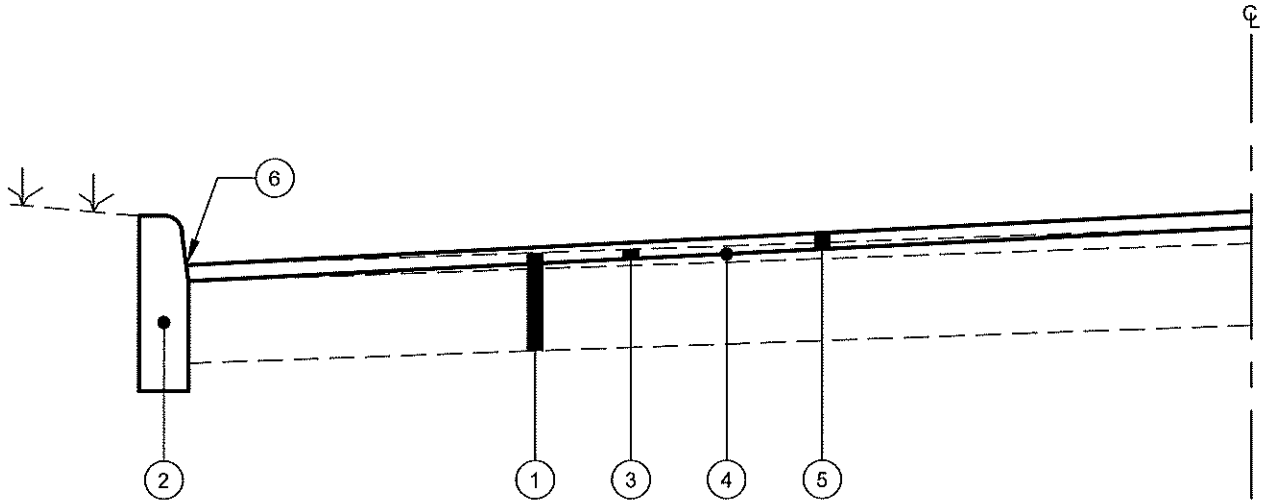

LEGEND

- ① EXISTING ASPHALT
- ② EXISTING CONCRETE CURB - SPOT REPAIR BY CITY
- ③ SPEC. NO. 408 - ASPHALT PAVEMENT MILLING, VARIABLE DEPTH, 1.5" AT GUTTER / E/P TO 0" AT CENTERLINE
- ④ SPEC. NO. 406 - TACK COAT INCIDENTAL TO ⑤
- ⑤ ITEM 402/403 - 1.5" ASPHALT PAVEMENT SURFACE WITH FIBER REINFORCEMENT
- ⑥ APPLY HOT POURED JOINT SEALER WHERE ASPHALT SURFACE MEETS CURB, INCIDENTAL TO ⑤

NOTE:

APPLY HOT POURED JOINT SEALER AT CONSTRUCTION JOINTS AT BEGINNING AND END OF PROJECT LIMITS, INCIDENTAL TO ⑤



TYPICAL SECTION VERNON LANES

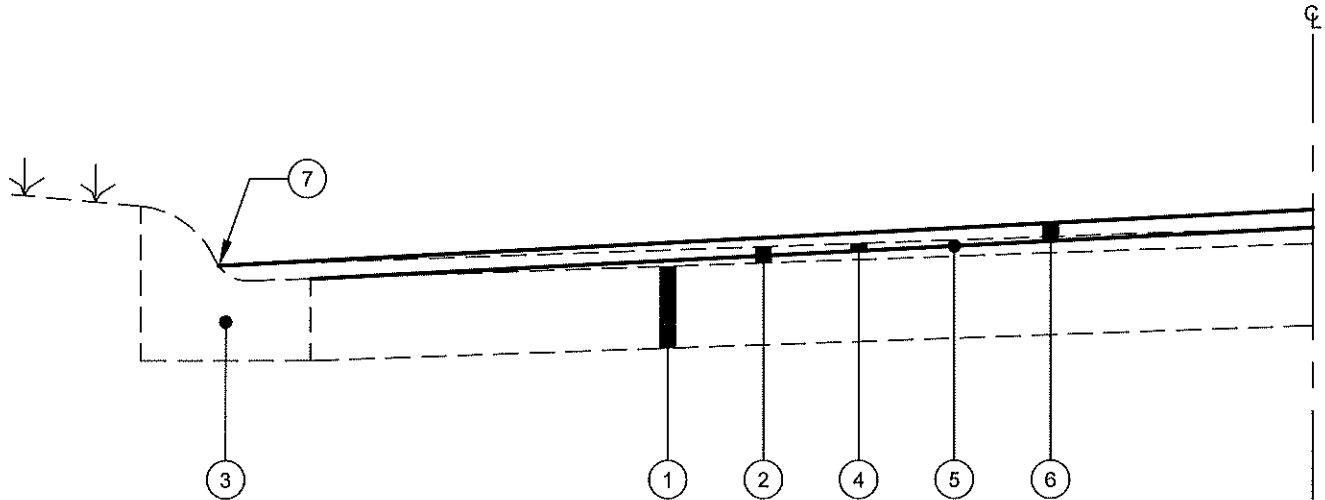

LEGEND

- ① EXISTING CONCRETE PAVEMENT
- ② EXISTING ASPHALT CONCRETE SURFACE COURSE
- ③ EXISTING CONCRETE CURB - SPOT REPAIR BY CITY
- ④ SPEC. NO. 408 - ASPHALT PAVEMENT MILLING, VARIABLE DEPTH, 1.5" AT GUTTER / E/P TO 0" AT CENTERLINE
- ⑤ SPEC. NO. 406 - TACK COAT INCIDENTAL TO ⑥
- ⑥ ITEM 402/403 - 1.5" ASPHALT PAVEMENT SURFACE WITH FIBER REINFORCEMENT
- ⑦ APPLY HOT POURED JOINT SEALER WHERE ASPHALT SURFACE MEETS CURB, INCIDENTAL TO ⑥

NOTE:

- 1.) APPLY HOT POURED JOINT SEALER AT CONSTRUCTION JOINTS AT BEGINNING AND END OF PROJECT LIMITS, INCIDENTAL TO ⑥
- 2.) A CONTINGENCY QUANTITY OF 402 / 403 ASPHALT PAVEMENT LEVELING COURSE IS INCLUDED IN THE CONTRACT. AFTER MILLING THE OWNER WILL REVIEW THE CONDITION OF THE SUBGRADE TO DETERMINE IF A LEVELING COURSE IS NEEDED.

