

NOTES:

- SEE LAYOUT PLAN FOR JOINT LOCATIONS. IF JOINTS ARE NOT SHOWN, THEN THE CONTRACTOR SHALL DETERMINE THE LOCATION OF ALL JOINTS. DIVIDE JOINTS INTO EQUALLY SPACED RECTANGULAR BLOCKS.
- IF UNSUITABLE SOILS EXIST, UNDERCUT SUBGRADE, REMOVE AND REPLACE WITH ODOT ITEM 304 CRUSHED LIMESTONE, 12" MIN.
- APPLY LIQUID-MEMBRANE CURING COMPOUND (225 S.F./GAL.)

9" REINFORCED CONCRETE PAVEMENT DETAIL
SCALE: NONE

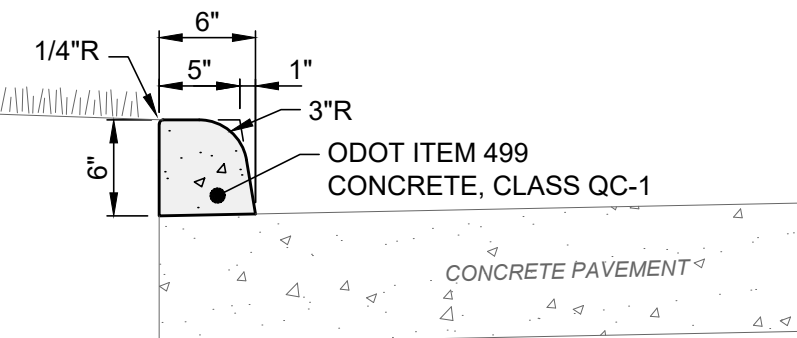

(ODOT TYPE 2A) 6" INTEGRAL VERTICAL CURB DETAIL
SCALE: NONE

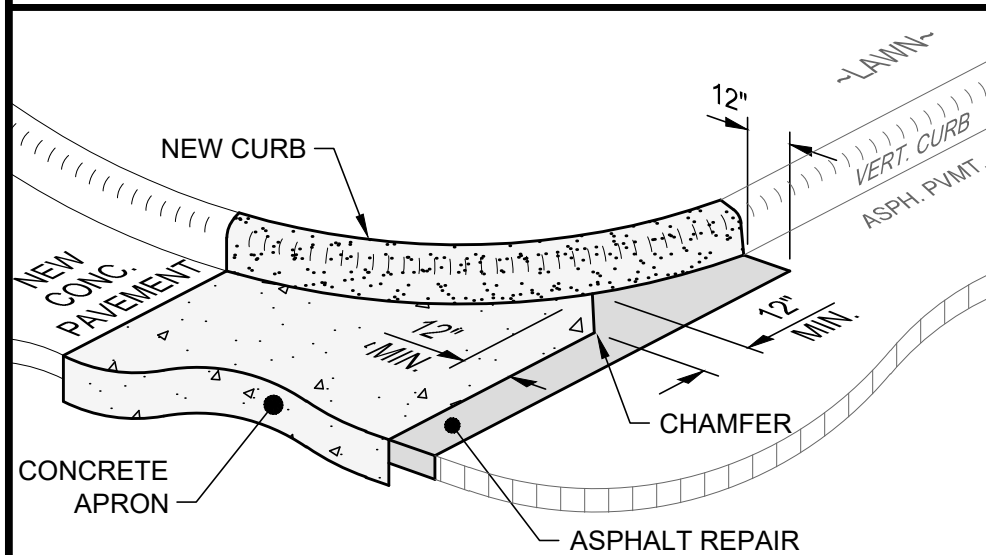

NOTES:

- SEE SEPARATE DETAILS FOR ASPHALT AND CONCRETE PAVEMENTS, CURB AND SUBBASE REQUIREMENTS.
- THIS DETAIL IS FOR REFERENCE ONLY. SEE LAYOUT PLAN FOR ACTUAL CONFIGURATION AND DIMENSIONS.

CONCRETE DRIVE FLUSH WITH EX. ASPHALT PAVEMENT DETAIL
SCALE: NONE

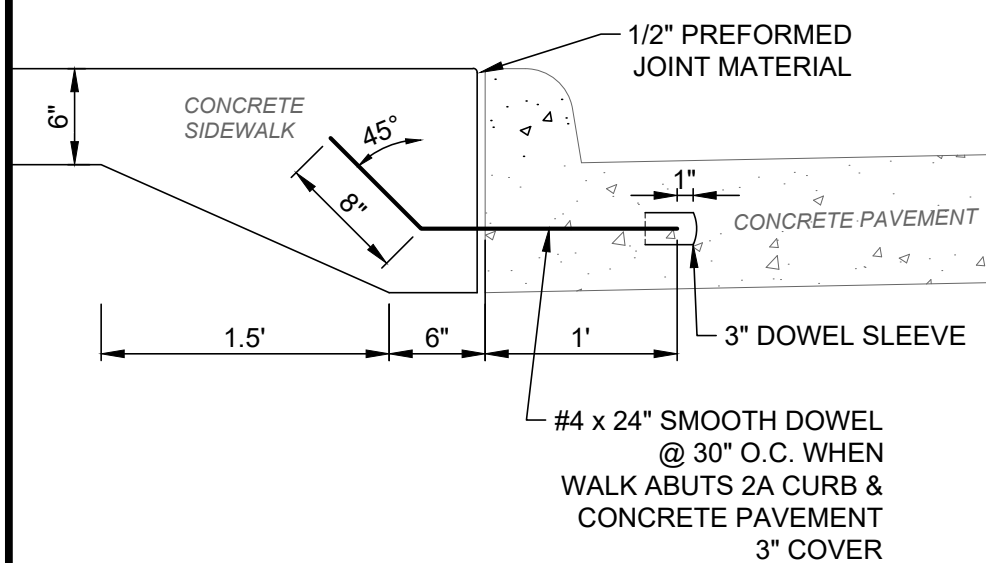

CONCRETE SIDEWALK ADJACENT TO 2A CURB
SCALE: NONE

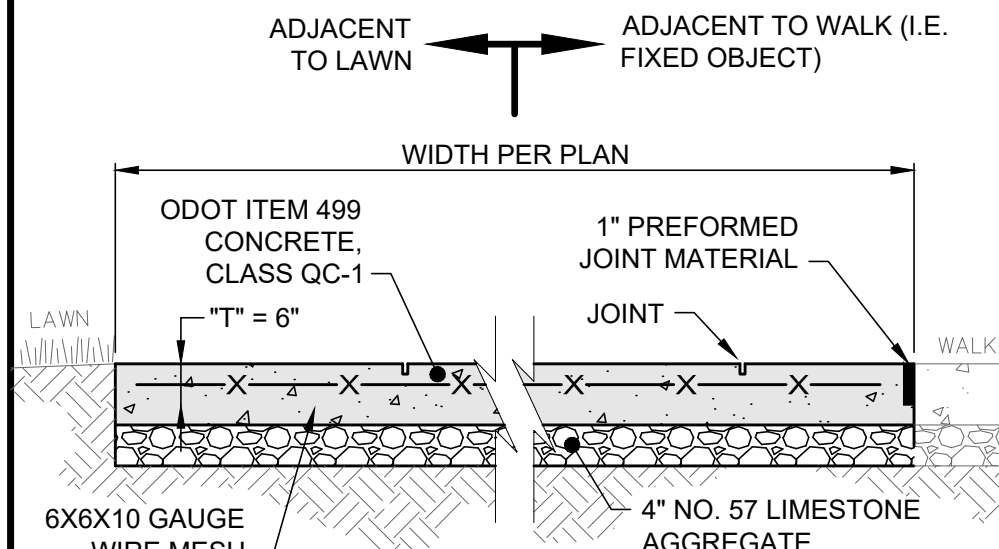

NOTES:

- SEE LAYOUT PLAN FOR JOINT LOCATIONS. IF JOINTS ARE NOT PROVIDED, THEN THE CONTRACTOR SHALL DETERMINE THE LOCATION OF ALL JOINTS. DIVIDE JOINTS INTO EQUALLY SPACED RECTANGULAR BLOCKS.
- SAW CUT OR HAND TOOL JOINT 1/8" WIDE BY 1/4 OF "T" DEEP.
- ROUND ALL EDGES AND JOINTS WITH A 1/4" RADIUS.
- INSTALL PREFORMED JOINT MATERIAL EVERY 30', OR BETWEEN SIDEWALK AND FIXED OBJECT (I.E. MANHOLE, WALK, BUILDING), WALK SHOWN FOR REFERENCE ONLY.
- LIGHTLY BROOM THE FINISH PERPENDICULAR TO THE WALKING PATH OR PER PLAN. IF HAND TOOLED JOINTS AND EDGES ARE SPECIFIED, FINISH AFTER PANEL INTERIOR TEXTURE HAS BEEN APPLIED (I.E. WINDOW PANE EFFECT).
- 4" NO. 57 LIMESTONE IS INCIDENTAL TO AND SHALL BE INCLUDED IN UNIT PRICE OF SIDEWALK.
- APPLY LIQUID-MEMBRANE CURING COMPOUND.

CONCRETE WALK DETAIL
SCALE: NONE

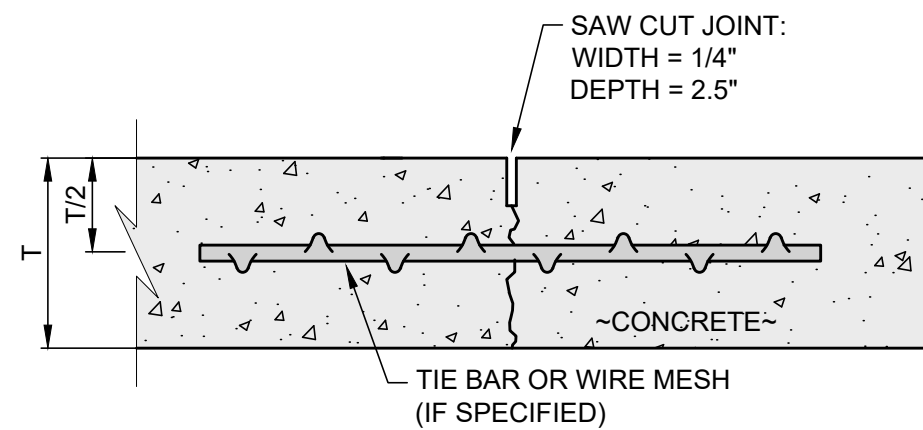

NOTES:

- ALL JOINTS SHALL BE CLEANED AND LEFT UNSEALED.

CONTRACTION JOINT DETAIL
SCALE: NONE

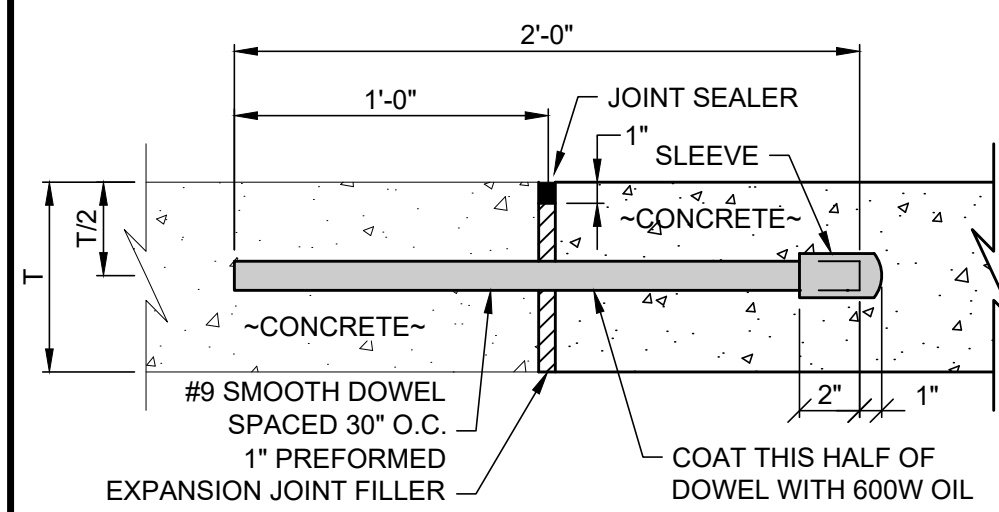

EXPANSION JOINT DETAIL
SCALE: NONE

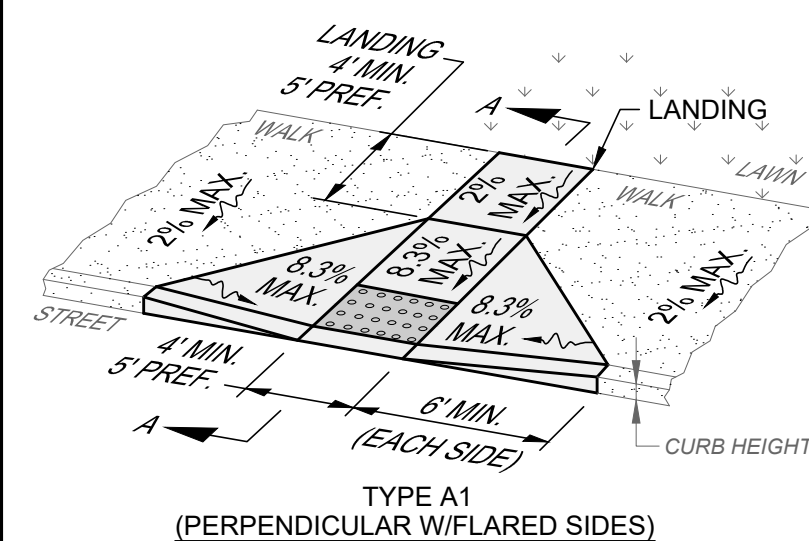

TYPE A1 (PERPENDICULAR W/FLARED SIDES)

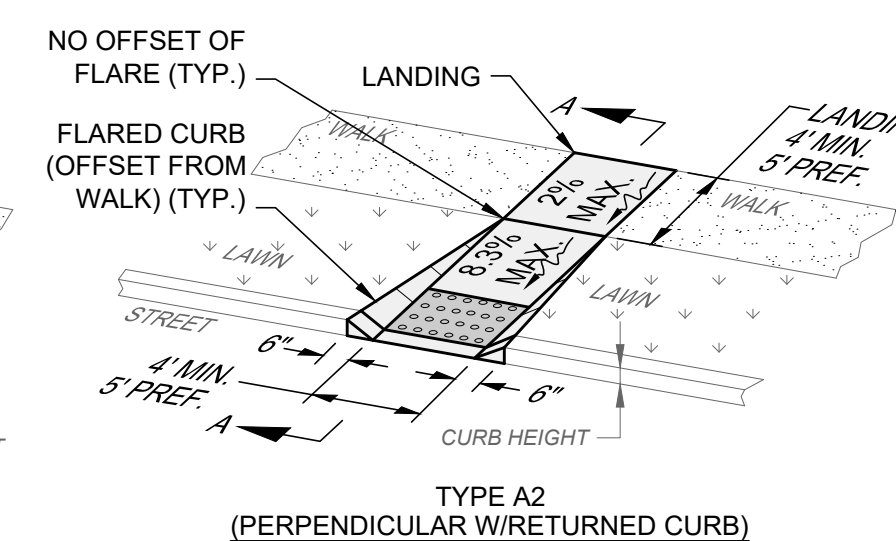

TYPE A2 (PERPENDICULAR W/RETURNED CURB)

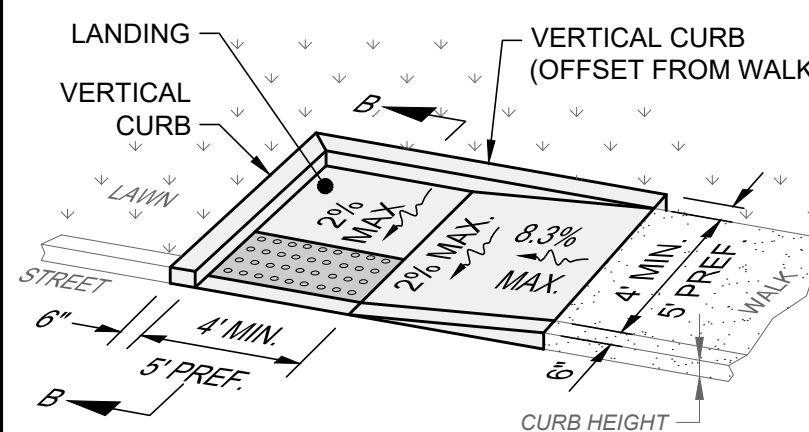

TYPE B1 (SINGLE SIDED PARALLEL)

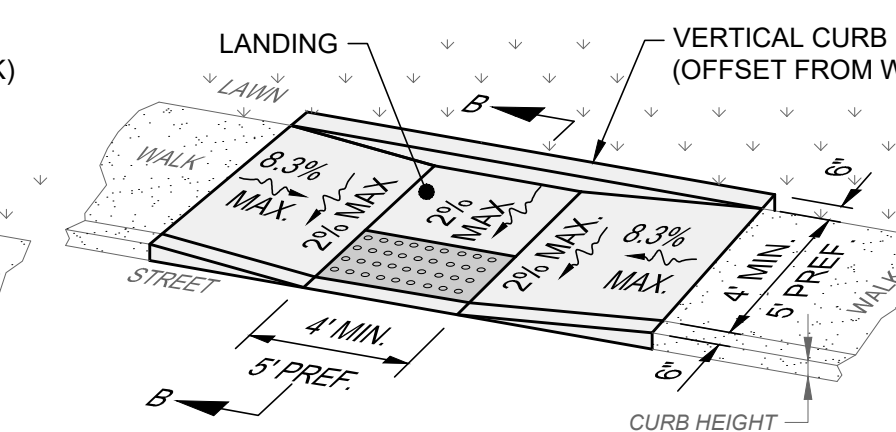

TYPE B2 (DOUBLE SIDED PARALLEL)

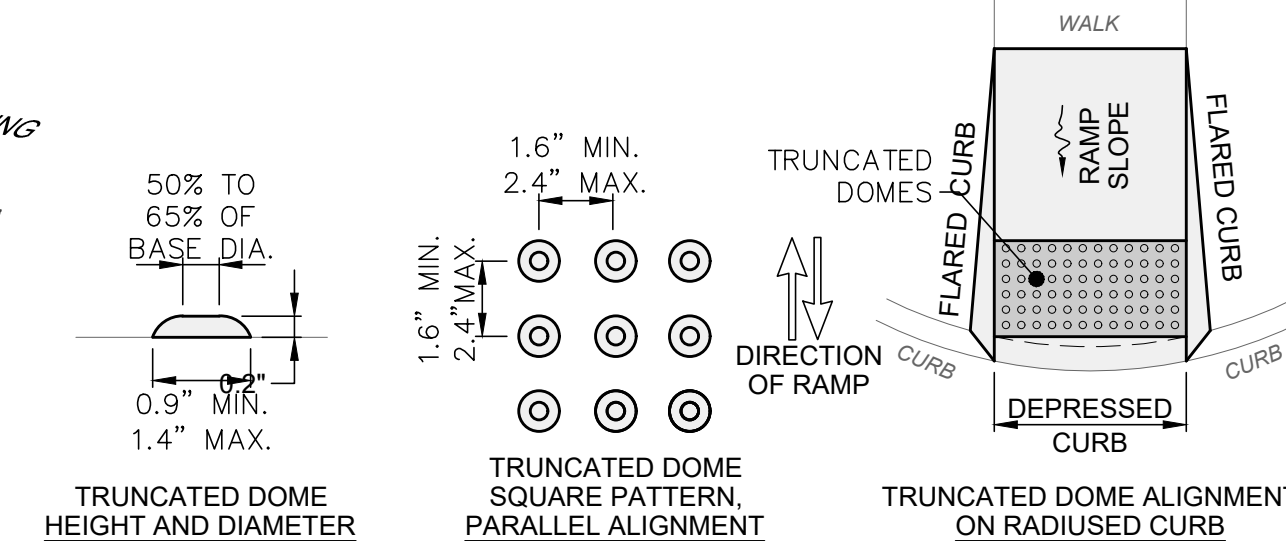

TRUNCATED DOME HEIGHT AND DIAMETER

TRUNCATED DOME SQUARE PATTERN, PARALLEL ALIGNMENT

TRUNCATED DOME ALIGNMENT ON RADIUS CURB

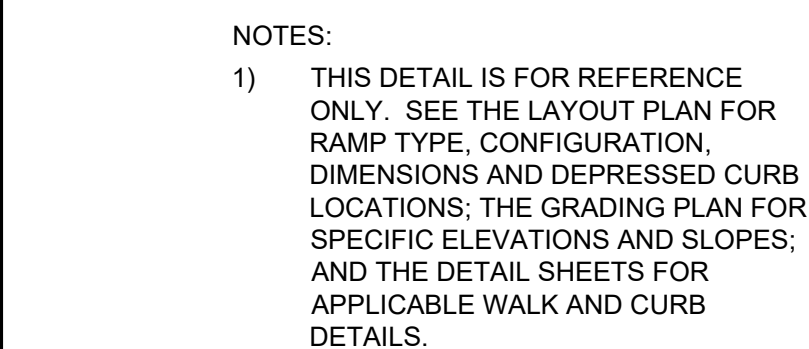

SECTION A-A (NORMAL DETAIL)

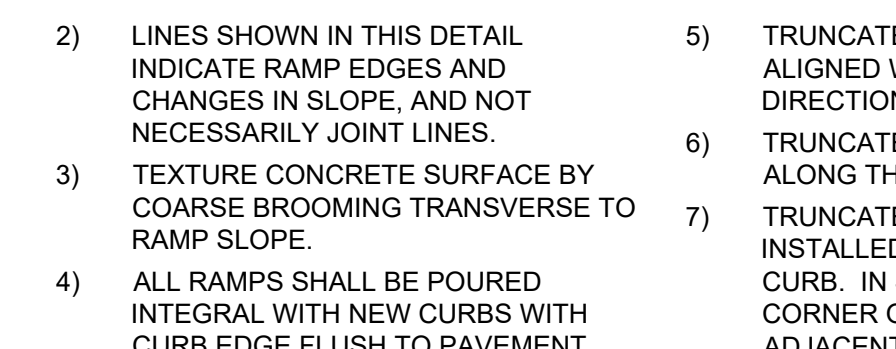

SECTION A-A (EX. WALK DETAIL)

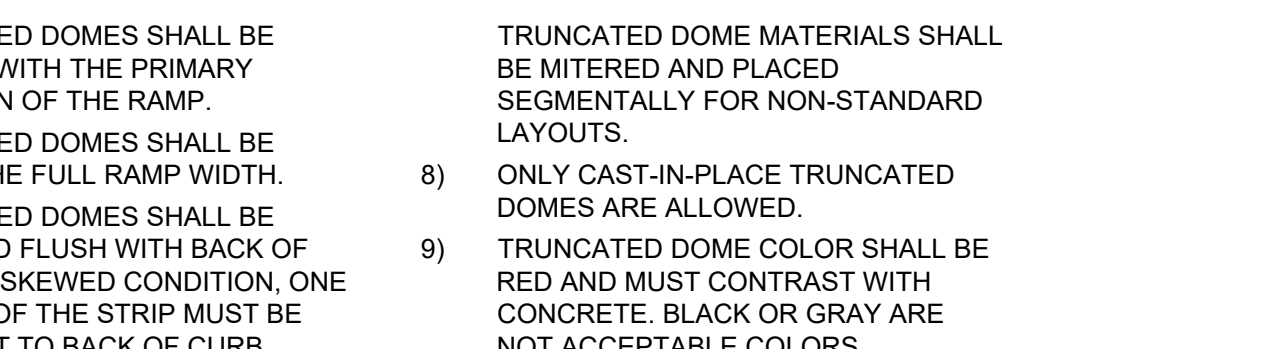

SECTION B-B

SECTION C-C

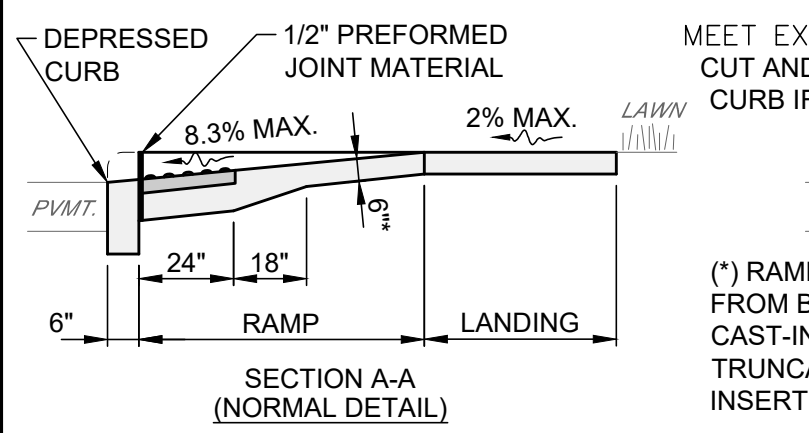

SECTION A-A (NORMAL DETAIL)

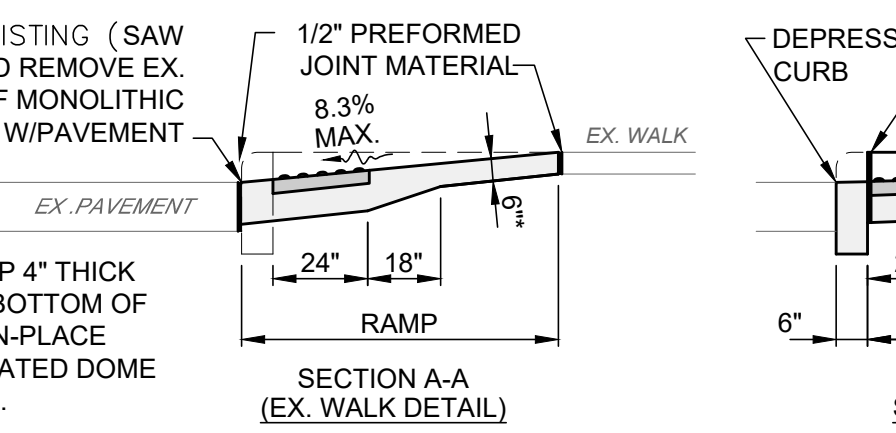

SECTION A-A (EX. WALK DETAIL)

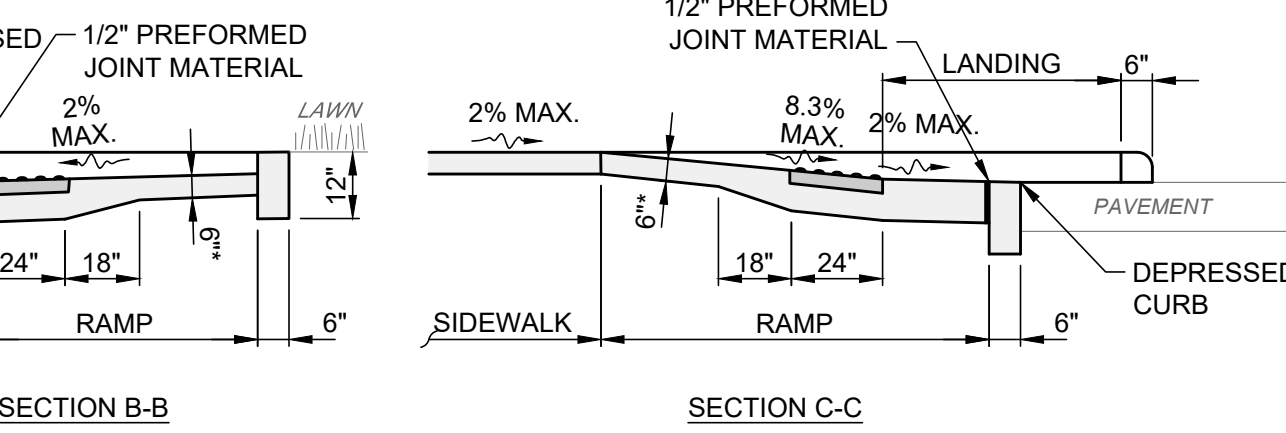

SECTION B-B

SECTION C-C

CURB RAMP WITH DETECTABLE WARNING DETAILS
SCALE: NONE

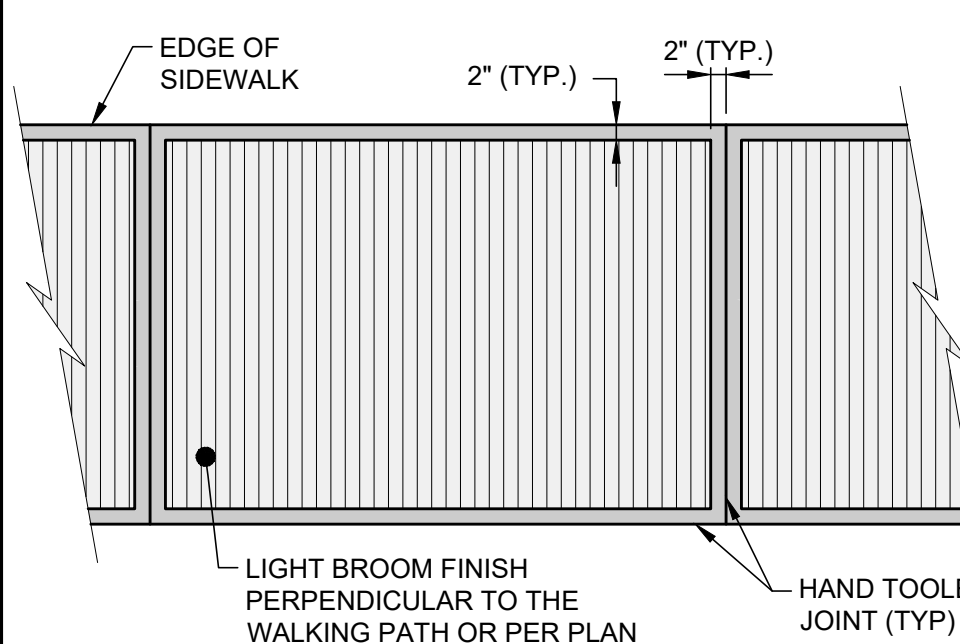

NOTES:

- HAND TOOLED JOINTS SHALL BE APPLIED TO CREATE A "WINDOW PANE" EFFECT AROUND EACH PANEL.
- ALL HAND TOOLED JOINTS AND EDGES SHALL BE FINISHED AFTER PANEL INTERIOR TEXTURE HAS BEEN APPLIED.
- TOOLED EDGE SHALL BE 2" WIDTH EACH SIDE OF JOINT.

CONCRETE SIDEWALK JOINT AND FINISH DETAIL
SCALE: NONE

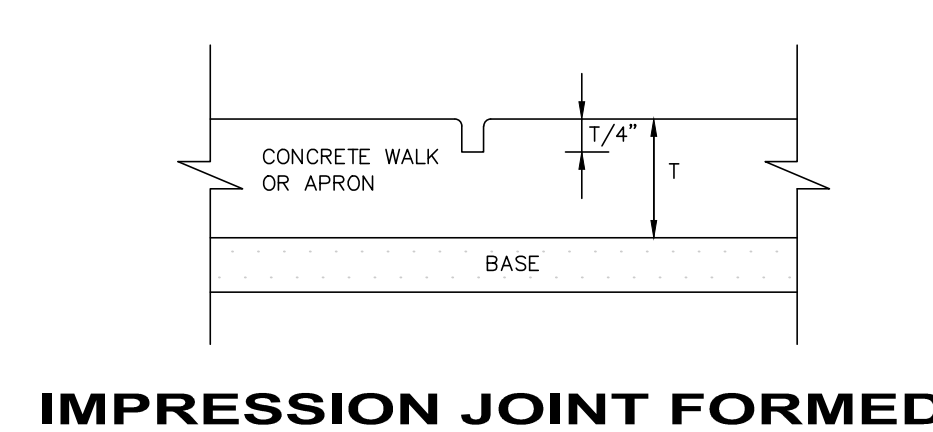

IMPRESSION JOINT FORMED

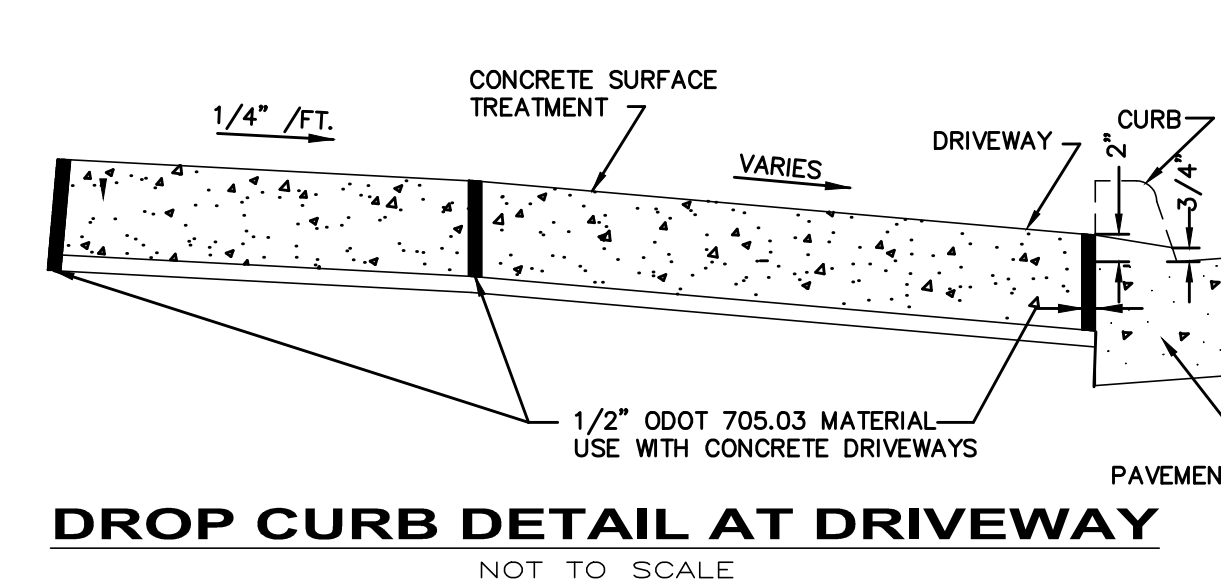

DROP CURB DETAIL AT DRIVEWAY
NOT TO SCALE

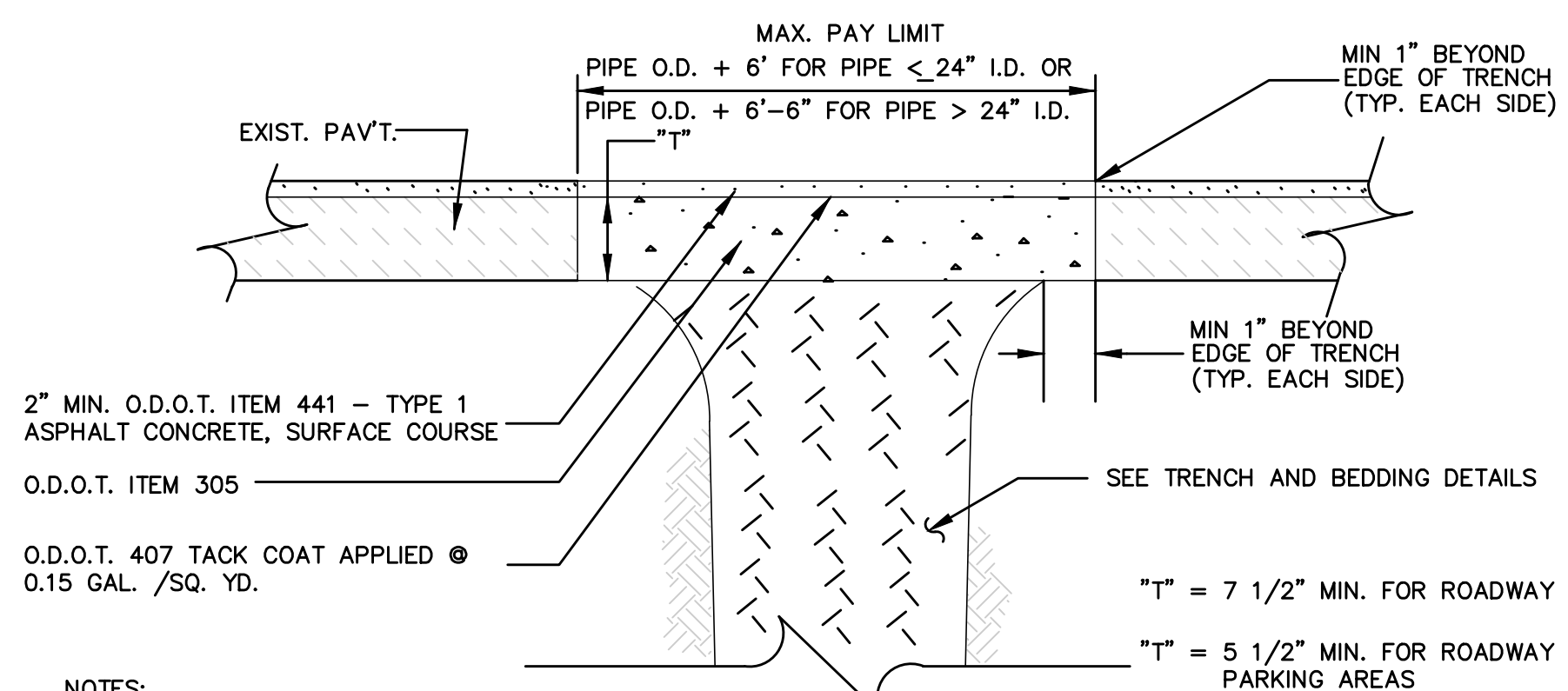

NOTES:

- EXISTING SUBBASE MATERIAL (IF ANY) SHALL BE REPLACED, AS DIRECTED BY ENGINEER.
- REPLACEMENT SHALL BE REINFORCED AS PER O.D.O.T. ITEM 709.10 OR 709.12 IF EXISTING PAVEMENT IS REINFORCED.
- 5/8" HOOKBOLT @ 30" O.C. MAY BE REQUIRED AS DIRECTED BY THE ENGINEER.

IN NO CASE SHALL THE THICKNESS OF THE ASPHALT OVERLAY AND/OR "T" BE LESS THAN EXISTING.

TYPE B PAVEMENT REPLACEMENT

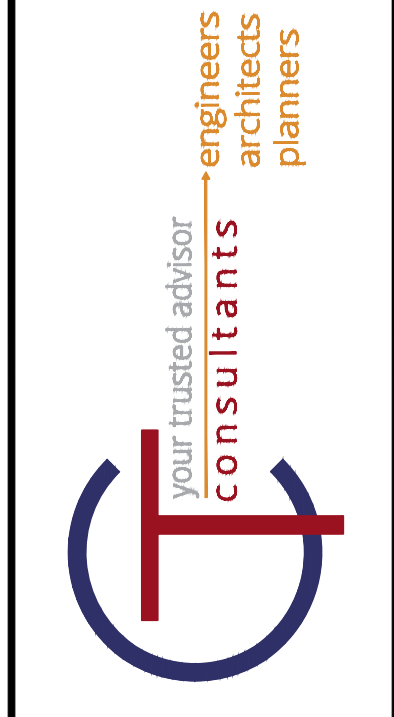

DATE	REVISION	NO	CD	ISSUED FOR:	ISSUE DATE:	SCALE:	DESIGNED BY:	DRAWN BY:	CHECKED BY:
			4/10/20	AS NOTED		PJF / GMS	PJF	PJF	PJF

LAKETRAN WICKLIFFE PARK-N-RIDE LOT
29610 LAKELAND BLVD., WICKLIFFE, OH 44092

CONSTRUCTION DETAILS 1

PROJECT NO.	190065
DISCIPLINE	CIVIL
SHEET NAME	DT-1
SHEET	12
OF	49