

**CLASS "C" PIPE EMBEDMENT**

- EXCAVATED TRENCH WIDTH: MEASURED FROM BOTTOM OF TRENCH TO 12" OVER TOP OF PIPE (WITHIN THE PIPE EMBEDMENT), THE MIN. TRENCH WIDTH SHALL BE 9" AND THE MAX. SHALL BE:
  - O.D. +24" FOR 24" AND SMALLER I.D. PIPE
  - O.D. +30" FOR 27" THRU 72" I.D. PIPE
  - O.D. +48" FOR 84" AND LARGER I.D. PIPE

- FINAL BACKFILL: ALL AREAS UNDER PAVEMENT, STRUCTURES OR WITHIN THE ZONE OF INFLUENCE SHALL BE PREMIUM BACKFILL (ODOT ITEM 304 LIMESTONE). PAVEMENT INCLUDES ROADWAY, SHOULDER AND DRIVEWAY, BUT NOT SIDEWALK. NO SLAG OR SLACKER AGGREGATES ALLOWED. IN ALL OTHER AREAS, THE FINAL BACKFILL SHALL BE SUITABLE ON-SITE MATERIAL.

- PIPE EMBEDMENT:
  - CLASS "A": SHALL BE USED FOR ALL PIPES UNDER PAVEMENT OR STRUCTURES WITH LESS THAN 12" OF PIPE COVER TO THE SUBGRADE. THE CONCRETE CRADLE SHALL BE IN ACCORDANCE WITH ODOT ITEM 499, CLASS QC-1. THE INITIAL BACKFILL SHALL BE NO. 57 COURSE INTERLOCKING LIMESTONE AGGREGATE.
  - CLASS "B": SHALL BE USED FOR ALL PIPES UNLESS OTHERWISE NOTED ON THE PLANS. BEDDING AND HAUNCHING SHALL BE NO. 8 OR 57 COURSE INTERLOCKING LIMESTONE AGGREGATE. IN AREAS UNDER PAVEMENT, STRUCTURES OR WITHIN THE ZONE OF INFLUENCE, THE INITIAL BACKFILL SHALL BE NO. 8 OR 57 COURSE INTERLOCKING LIMESTONE AGGREGATE. IN ALL OTHER AREAS, THE INITIAL BACKFILL MAY BE SUITABLE ON-SITE MATERIAL FOR RIGID PIPE, AND SHALL BE NO. 8 OR 57 COURSE INTERLOCKING LIMESTONE AGGREGATE FOR FLEXIBLE PIPE.
  - CLASS "C": SHALL BE USED ONLY FOR DUCTILE IRON WATER MAIN OR FORCE MAIN. THE PIPE EMBEDMENT SHALL BE NO. 8 OR 57 COURSE INTERLOCKING LIMESTONE AGGREGATE IN ALL AREAS UNDER PAVEMENT, STRUCTURES OR WITHIN THE ZONE OF INFLUENCE. IN ALL OTHER AREAS, THE PIPE EMBEDMENT SHALL BE SUITABLE ON-SITE MATERIAL. BEDDING IS NOT REQUIRED. WHERE ROCK OR SHALE IS ENCOUNTERED, BEDDING SHALL BE 6" MIN. OF NO. 8 OR 57 COURSE INTERLOCKING LIMESTONE AGGREGATE OR SAND.

- SUBBEDDING: WHERE AN UNSTABLE TRENCH BOTTOM CONDITION IS ENCOUNTERED, EXCAVATE TO A DEPTH REQUIRED BY THE ENGINEER AND REPLACE WITH MATERIAL AS DIRECTED BY THE ENGINEER.

- GEOTEXTILE FABRIC SHALL BE PER ODOT 712.09, TYPE A, AND INSTALLED AFTER ALL INITIAL BACKFILL.

- CLAY TRENCH DAMS SHALL BE REQUIRED AS SHOWN ON PLANS OR AS DIRECTED BY THE ENGINEER.

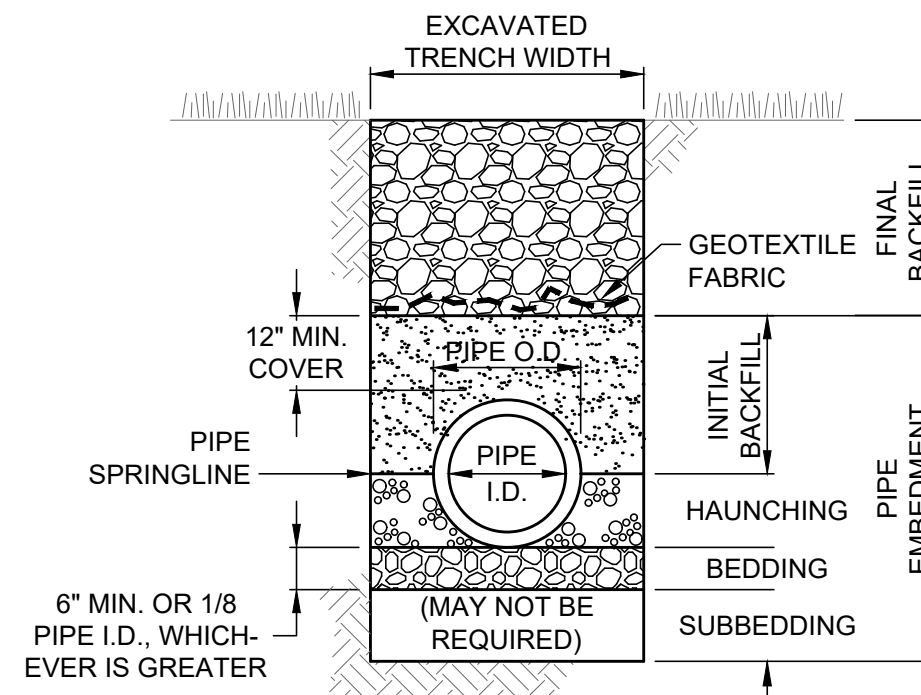

**CLASS "B" PIPE EMBEDMENT**

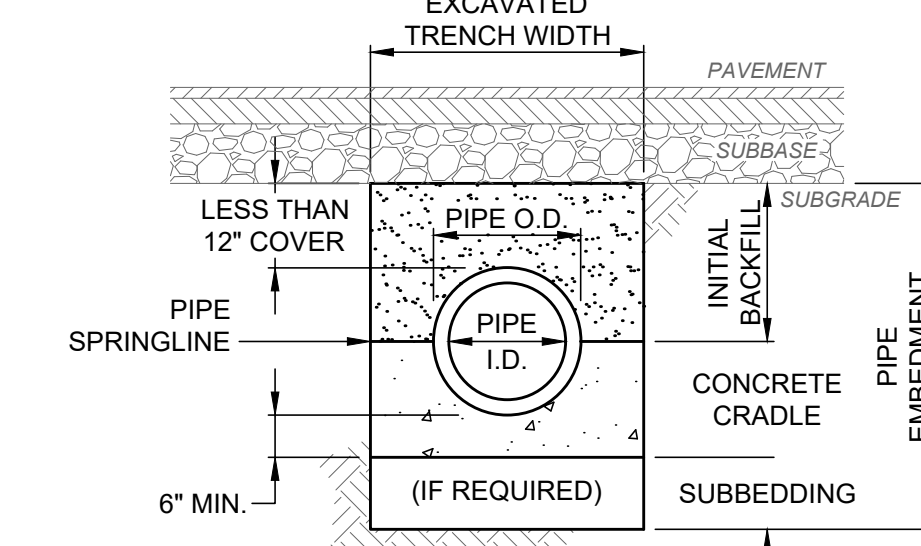

**CLASS "A" PIPE EMBEDMENT**

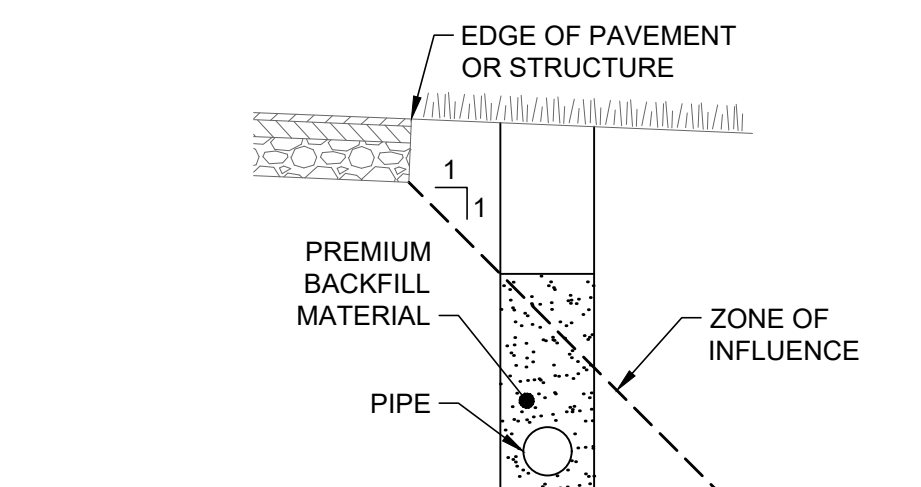

**PARALLEL ZONE OF INFLUENCE**

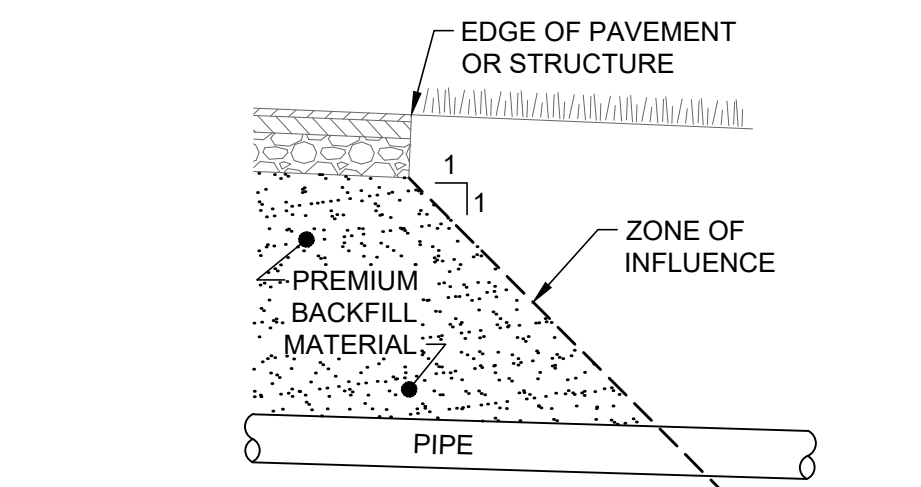

**TRANSVERSE ZONE OF INFLUENCE**

**TRENCHING, EMBEDMENT AND BACKFILL DETAIL**

SCALE: NONE

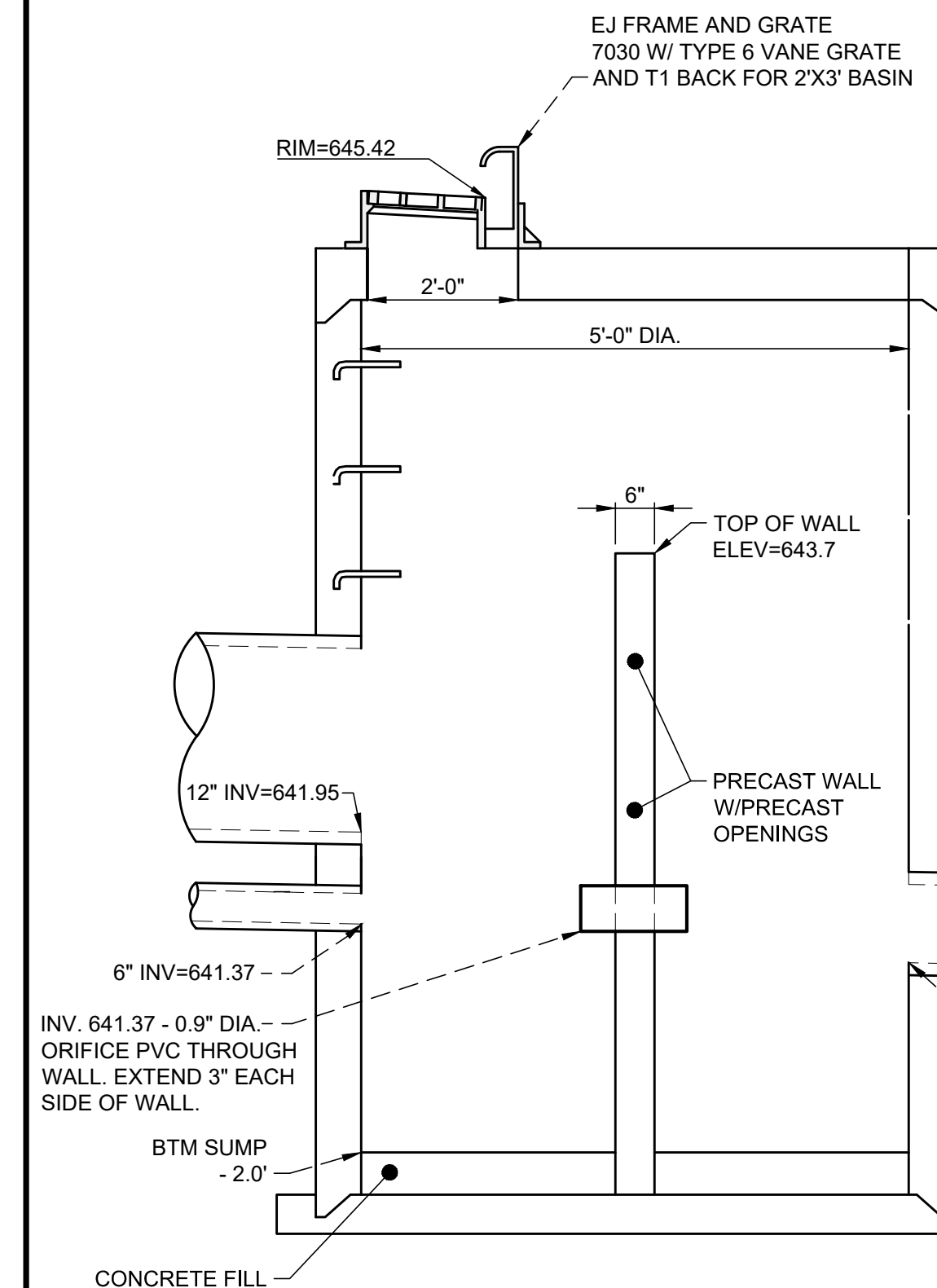

NOTES:

- THIS DETAIL PROVIDES ADDITIONAL INFORMATION RELATED TO THE SPECIFIC OUTLET CONTROL STRUCTURE INCLUDING ELEVATIONS AND PIPE DIRECTIONS. SEE PRE-CAST CONCRETE CURB INLET BASIN DETAIL FOR INLET SPECIFICATIONS, DIMENSIONS, ETC.
- STEPS TO BE CONSTRUCTED.

**STORM WATER OUTLET CONTROL STRUCTURE DETAIL**

SCALE: NONE

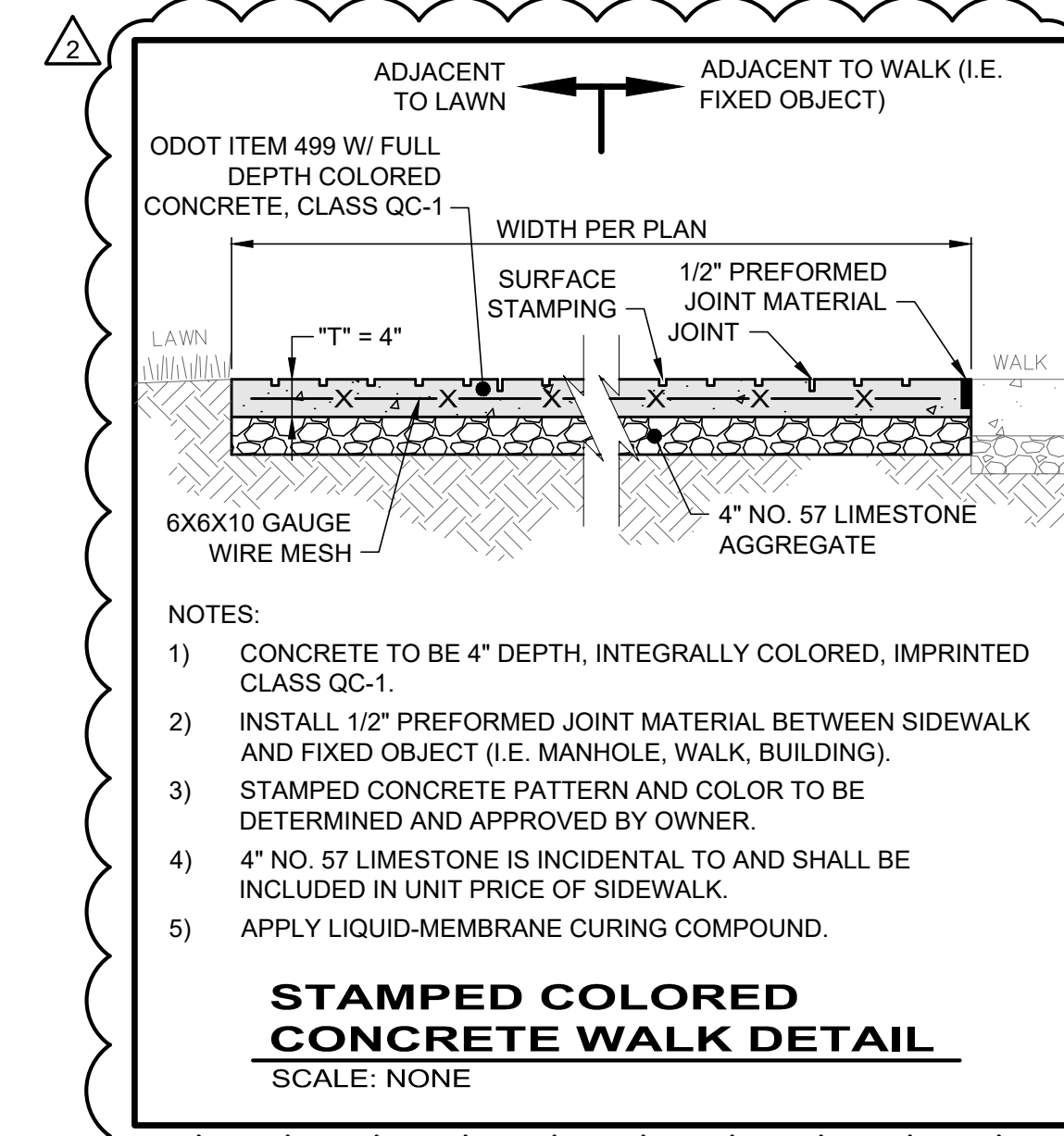

NOTES:

- CONCRETE TO BE 4" DEPTH, INTEGRALLY COLORED, IMPRINTED CLASS QC-1.
- INSTALL 1/2" PREFORMED JOINT MATERIAL BETWEEN SIDEWALK AND FIXED OBJECT (I.E. MANHOLE, WALK, BUILDING).
- STAMPED CONCRETE PATTERN AND COLOR TO BE DETERMINED AND APPROVED BY OWNER.
- 4" NO. 57 LIMESTONE IS INCIDENTAL TO AND SHALL BE INCLUDED IN UNIT PRICE OF SIDEWALK.
- APPLY LIQUID-MEMBRANE CURING COMPOUND.

**STAMPED COLORED CONCRETE WALK DETAIL**

SCALE: NONE

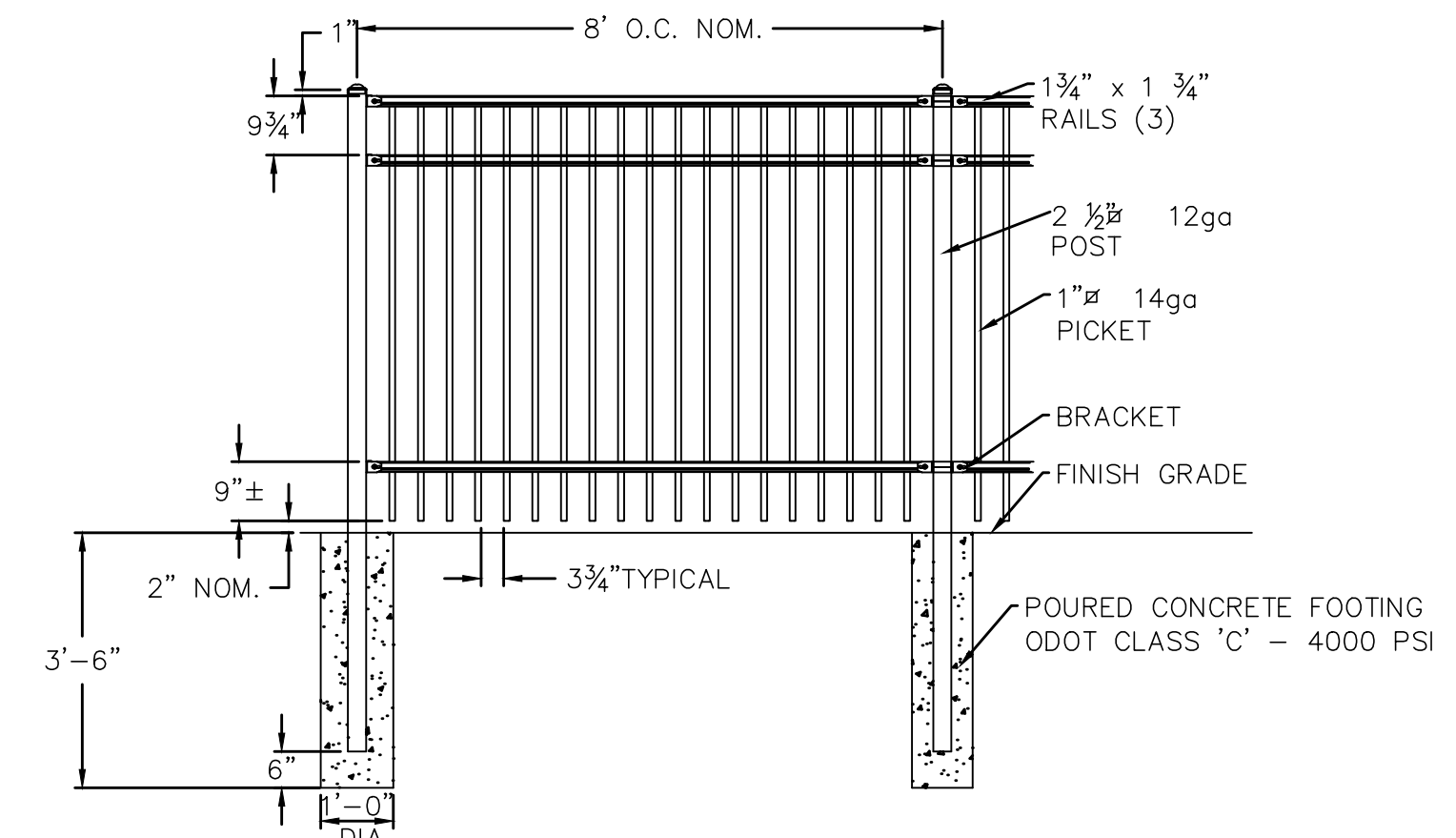

**ALUMINUM 5' ORNAMENTAL FENCE DETAIL (ALT.)**

ODOT-697

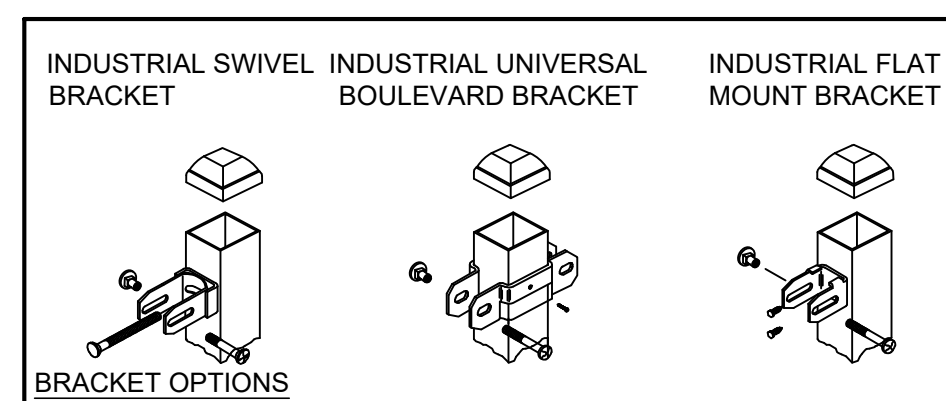
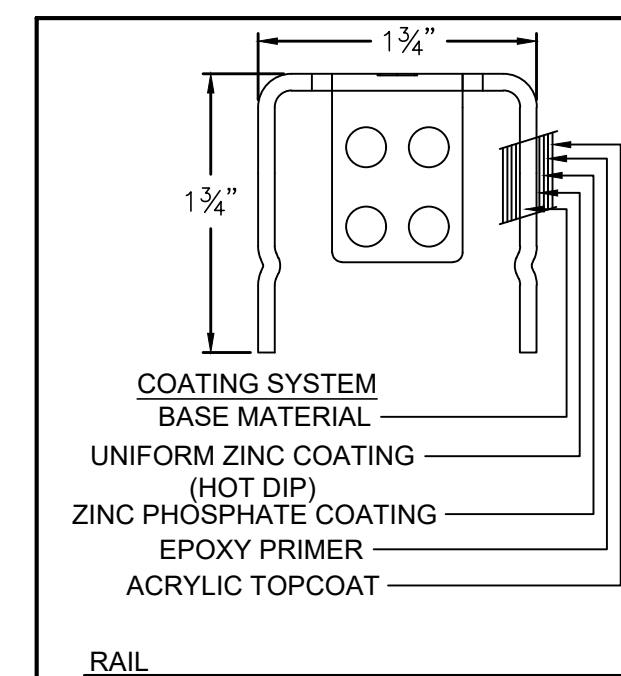

**MISC. FENCE DETAILS**

RAKING DIRECTIONAL ARROW WELDED PANEL SHALL BE FABRICATED SO AS TO BE ABLE TO BE RAKED 30° OVER 8' WITH ARROW POINTING DOWN GRADE.

WELD PICKETS TO RAILS (WELDS SHALL BE "HIDDEN" WITHIN RAILS)

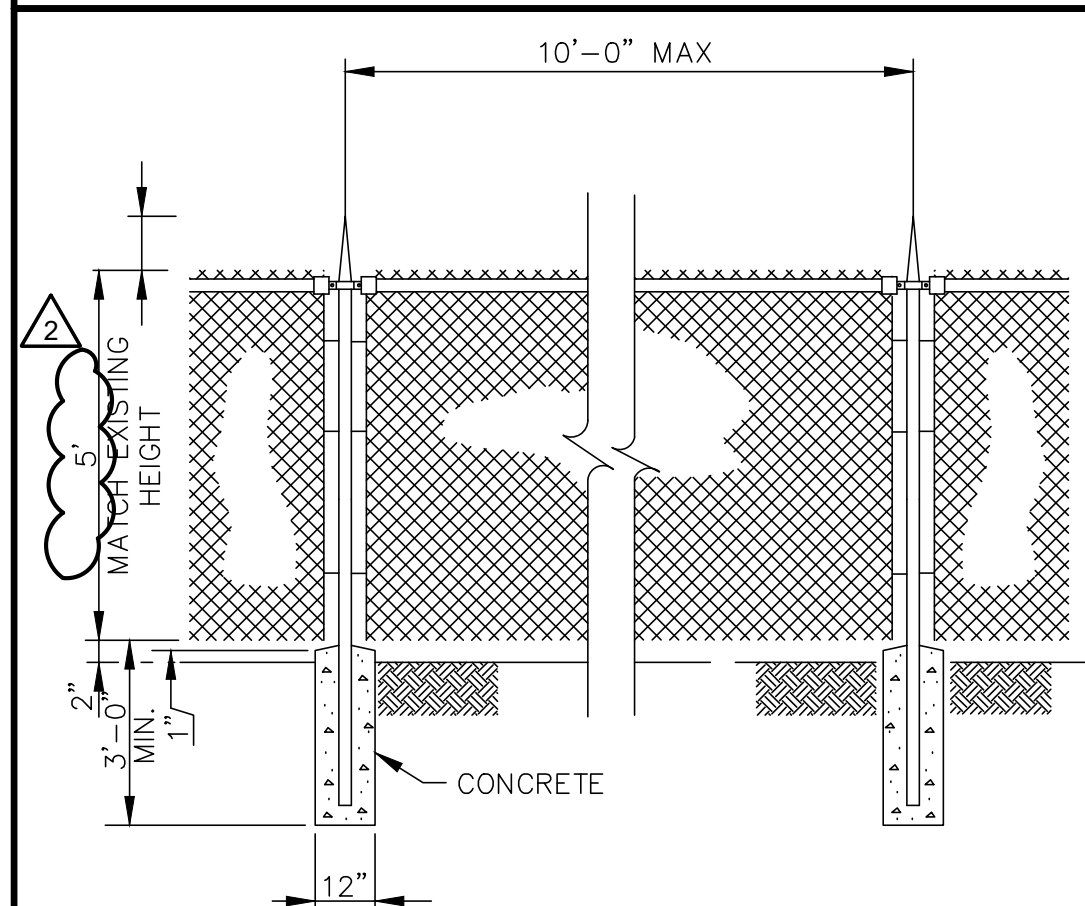

**TYPICAL FENCE ASSEMBLY**

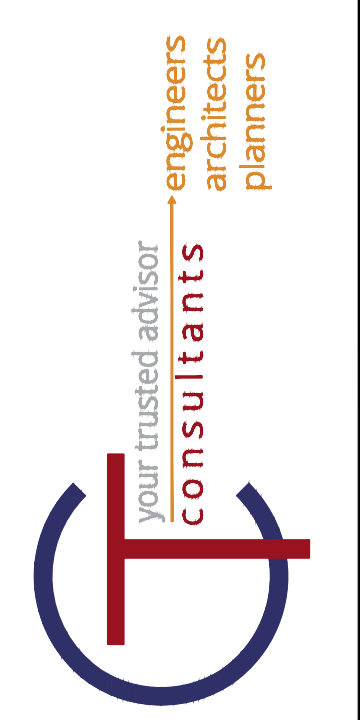
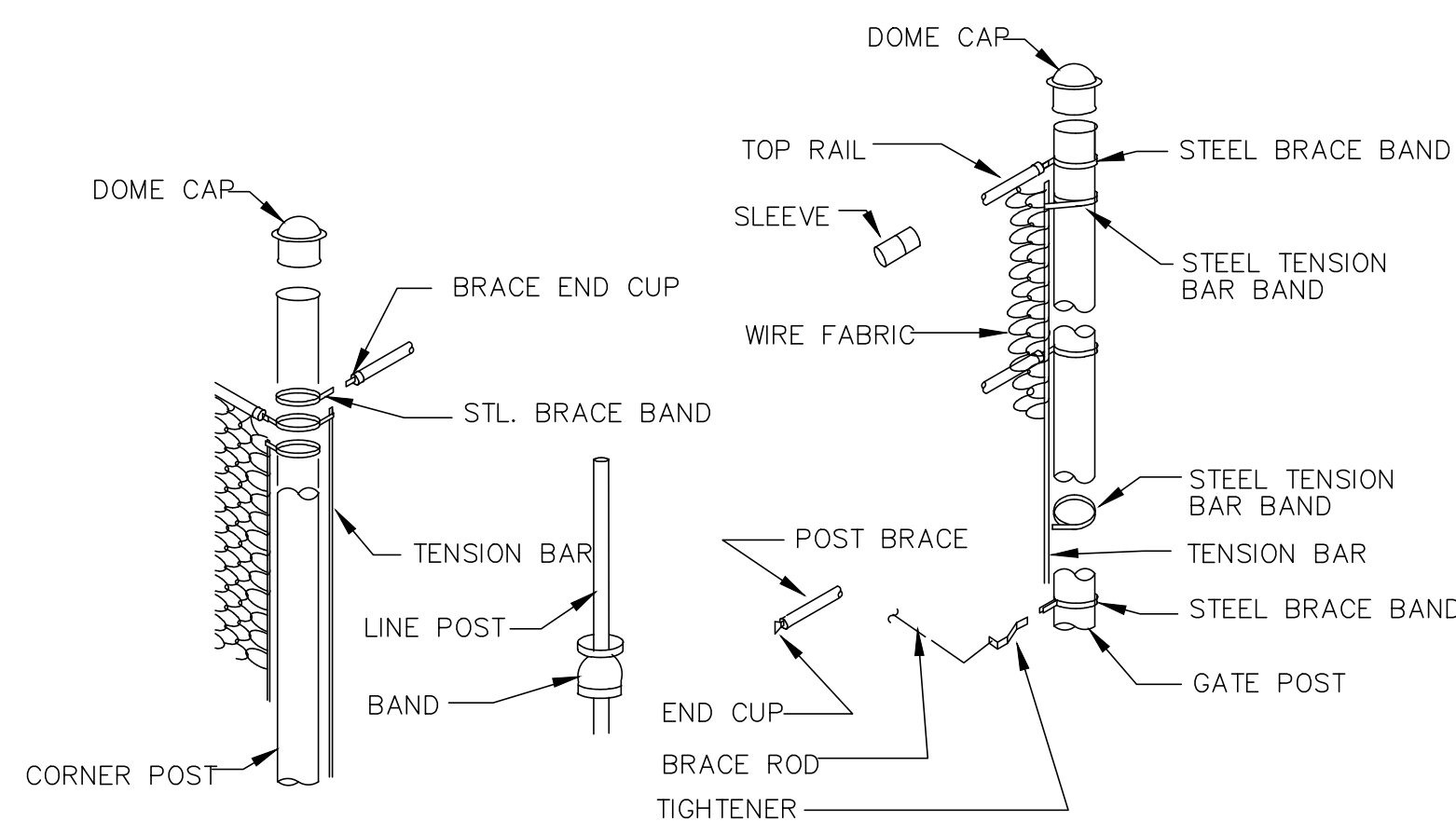

DATE	5/06/20
REVISION	ADDENDUM 2
NO.	2
ISSUED FOR:	CD
ISSUE DATE:	4/10/20
SCALE:	AS NOTED
DESIGNED BY:	PJF / GMS
DRAWN BY:	GMS
CHECKED BY:	PJF

**LAKETRAN WICKLIFFE PARK-N-RIDE LOT**  
 29610 LAKELAND BLVD., WICKLIFFE, OH 44092

PROJECT NO.	190065
DISCIPLINE	CIVIL
SHEET NAME	DT-6
SHEET	17
OF	49

**CONSTRUCTION DETAILS 6**