

# ELECTRICAL SERVICE LOAD SUMMARY

LOAD	KW CONNECTED	DEMAND FACTOR	KW DEMAND	NOTES
INTERIOR LIGHTING	0.8	100%	0.8	
EXTERIOR LIGHTING	5.3	100%	5.3	
CONVENIENCE RECEPTACLES	3.3	NEC	3.3	
MISC. BUILDING EQUIPMENT	6.4	50%	3.2	
MISC. MECHANICAL EQUIPMENT	2.1	100%	2.1	
AIR CONDITIONING EQUIPMENT	23.3	100%	23.3	
(2) TWO BUS CHARGERS	1109.4	100%	1109.4	
<b>TOTALS</b>	<b>1150.6</b>	<b>-</b>	<b>1147.4</b>	<b>-</b>
SERVICE VOLTAGE: 480Y/277-3PH-4W		DEMAND AMPERES: 1381.7		

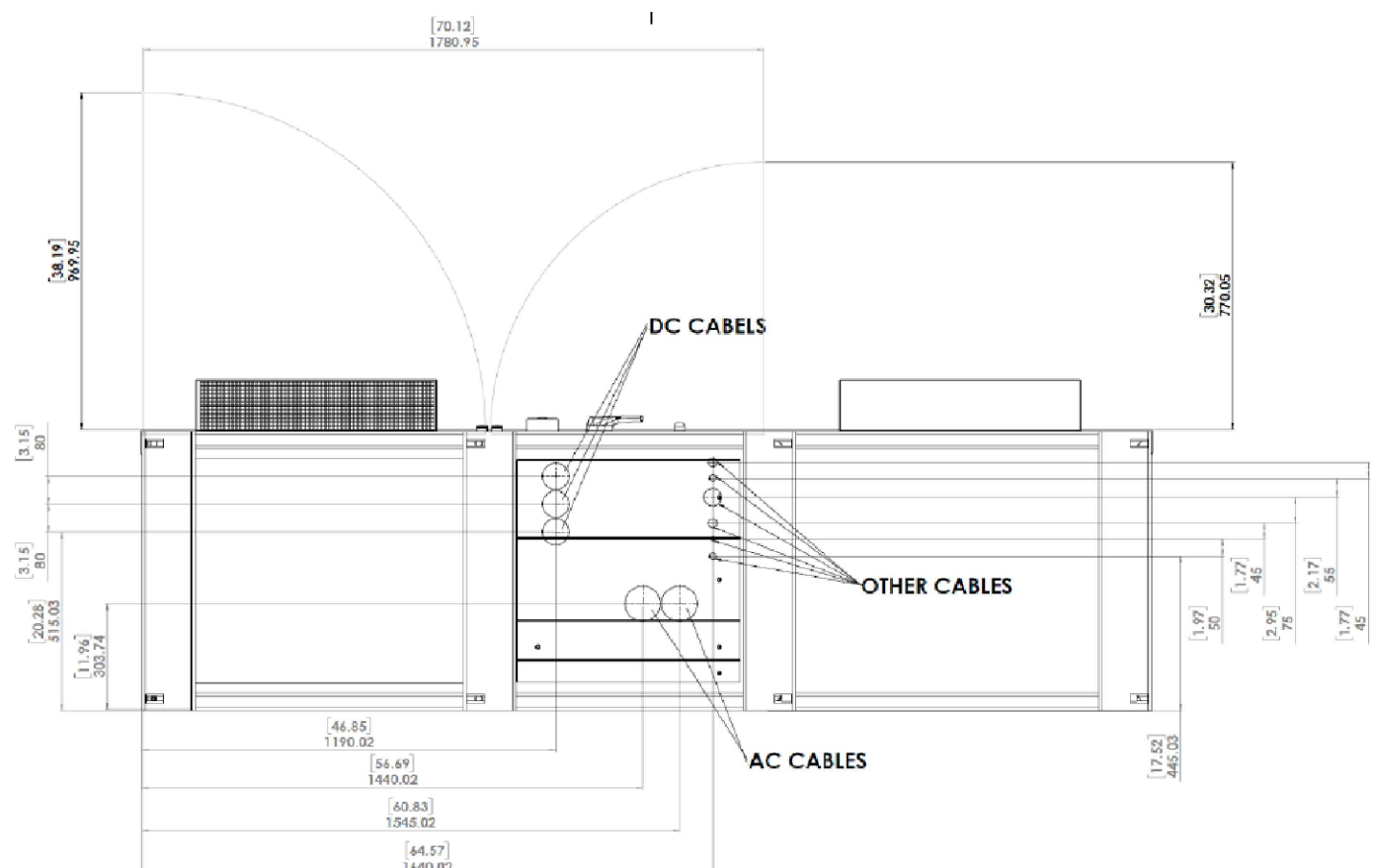

BOTTOM VIEW OF PROTERRA 500 KW CHARGING CABINET  
NO SCALE

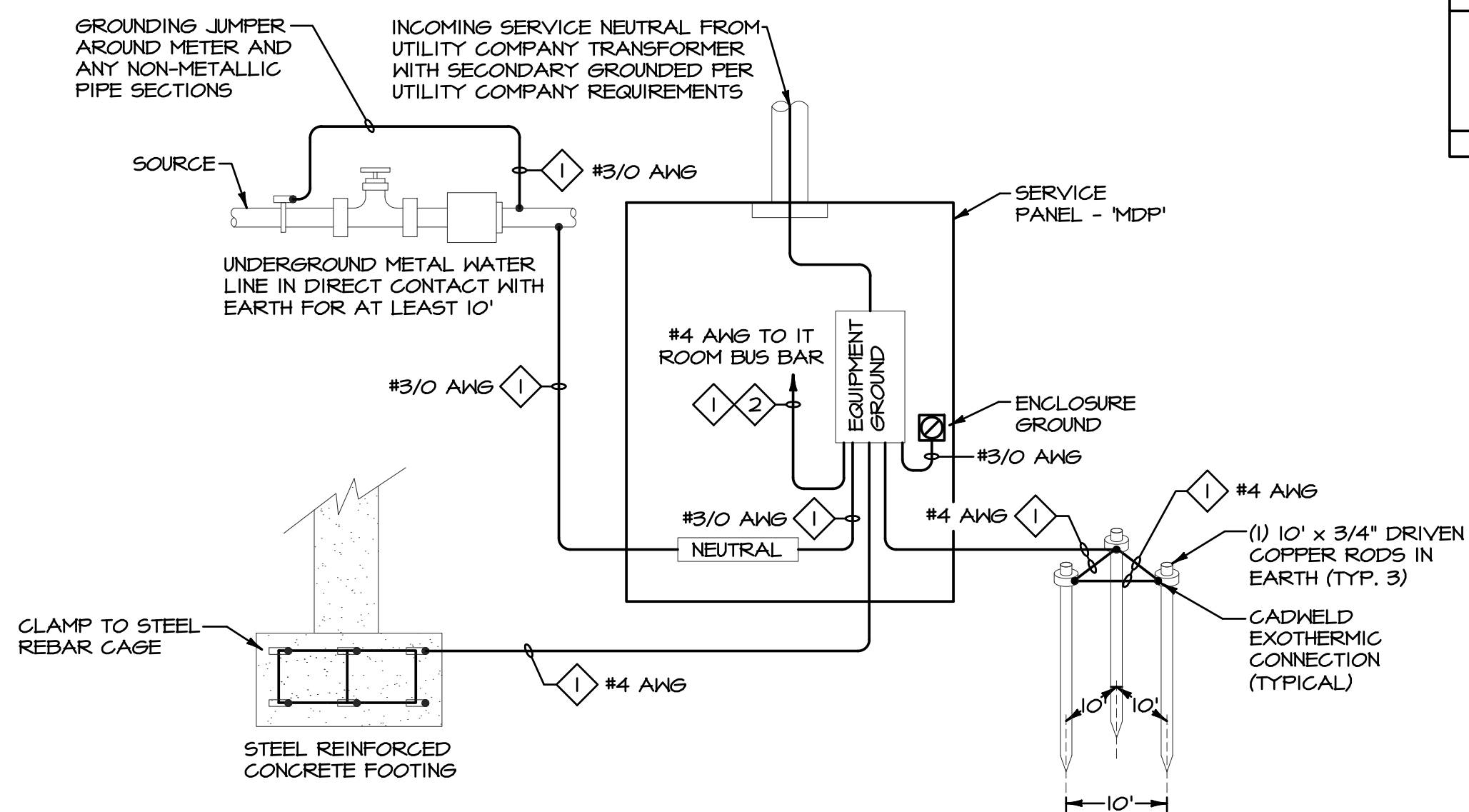

SERVICE GROUNDING ELECTRODE SYSTEM WIRING DIAGRAM  
NO SCALE

- 1 THE GROUNDING ELECTRODE CONDUCTORS SHALL BE SIZED PER TABLE 250-66 OF THE NEC. RUN CONCEALED IN AREAS OF FINISHED CONSTRUCTION, EXPOSED IN UN-FINISHED AREAS.
- 2 GROUND CONDUCTORS TO OTHER POINTS AND EQUIPMENT, AS REQUIRED BY NEC ARTICLE 250.

## GENERAL ELECTRICAL NOTES

- THE ELECTRICAL INSTALLATION MUST MEET OR EXCEED THE MINIMUM REQUIREMENTS OF THE LATEST EDITION OF THE NATIONAL ELECTRIC CODE AND ANY APPLICABLE STATE OR LOCAL CODES, AS INTERPRETED BY THE LOCAL AUTHORITY HAVING JURISDICTION.
- REFER TO THE ELECTRICAL SPECIFICATIONS FOR ADDITIONAL MATERIAL AND LABOR, SOME OF WHICH MAY NOT BE DETAILED ON THE FLOOR PLANS.
- VERIFY THE EXACT LOCATION AND MOUNTING HEIGHTS OF WALL, FLOOR AND CEILING MOUNTED DEVICES AND EQUIPMENT WITH THE ARCHITECTURAL ELEVATIONS, DETAILS, FLOOR AND CEILING PLANS AND WITH THE EXISTING CONDITIONS BEFORE ROUGH-IN OF THE ELECTRICAL WORK. DISCREPANCIES MUST BE BROUGHT TO THE ATTENTION OF THE OWNER'S REPRESENTATIVE FOR RESOLUTION PRIOR TO ROUGH-IN.
- CONFIRM THE CEILING TYPES IN ALL AREAS WITH THE GENERAL TRADES CONTRACTOR OR WITH THE EXISTING BUILDING CEILING CONDITIONS, AND FURNISH THE PROPER LIGHT FIXTURE TRIMS AND SUPPORTS TO SUIT EACH CEILING TYPE.
- BRANCH CIRCUIT WIRING FOR EMERGENCY LIGHTING BATTERY PACKS AND EXIT LIGHTS SHALL BE INSTALLED AND CONNECTED IN ACCORDANCE WITH ARTICLE 700 OF THE NATIONAL ELECTRICAL CODE.
- COORDINATE THE ELECTRICAL WORK WITH ALL TRADES ON SITE AND WITH THE OWNER'S REPRESENTATIVE. REFER TO THE PLANS AND DETAILS SHOWING THE ARCHITECTURAL, STRUCTURAL, MECHANICAL, PLUMBING AND TECHNOLOGY WORK TO PROPERLY PLAN AND INSTALL THE ELECTRICAL SYSTEMS AND EQUIPMENT.

## ELECTRICAL SYMBOLS

- A 3/5 BRANCH CIRCUIT HOMERUN TO PANEL "A", CIRCUIT #3 AND #5. PROVIDE THE PROPER QUANTITY OF 12 AWG CONDUCTORS FOR THE CIRCUIT(S) INDICATED. A SEPARATE GROUNDING CONDUCTOR IS REQUIRED FOR ALL BRANCH CIRCUITS.
- S SINGLE POLE SWITCH - MOUNTING AT 48" A.F.F.
- S<sup>OV</sup> LOW VOLTAGE BUILDING OVERRIDE SWITCH - SEE PLANS FOR ADDITIONAL DETAILS
- PHOTOCELL - MOUNTING AS NOTED ON PLAN
- M OCCUPANCY SENSOR SWITCH WITH OVERRIDE SWITCH - WALL MOUNTED AT 48" A.F.F. OR AS NOTED
- A LIGHT FIXTURE TYPE 'A'
- B LIGHT FIXTURE TYPE 'B'
- C LIGHT FIXTURE, WALL MOUNTED TYPE 'C'
- ▨ LIGHT FIXTURE ON EMERGENCY BRANCH CIRCUIT
- ⊙ EXIT SIGN - WALL MOUNTED ABOVE DOOR OR AT 7'-6" A.F.F. UNLESS OTHERWISE NOTED
- ⊕ DUPLEX RECEPTACLE - MOUNTING AT 18" A.F.F.
- ⊕⊕ TWO DUPLEX RECEPTACLES MOUNTED IN A 2-GANG BOX AT 18" A.F.F. UNLESS OTHERWISE NOTED
- ⊕<sup>36"</sup> DUPLEX RECEPTACLE - INDICATES MOUNTING AT 36" A.F.F.
- ⊕<sup>GFI</sup> DUPLEX RECEPTACLE - GROUND FAULT CIRCUIT INTERRUPTER (GFCI) TYPE
- ⊕<sup>TV</sup> DUPLEX RECEPTACLE - MOUNTED AT 84" A.F.F. FOR TELEVISION - U.O.N.
- ⊕<sup>USB</sup> GFCI TYPE DUPLEX RECEPTACLE IN WEATHERPROOF ENCLOSURE
- ⊕<sup>USB</sup> USB RECEPTACLE WITH (4) FOUR USB OUTLETS ONLY - TO BE HUBBELL #USB4 OR EQUAL BY LEVITON
- ⊕ JUNCTION BOX - MOUNTING HEIGHT AND SIZE AS REQUIRED
- PANELBOARD - 0 TO 150 VOLTS TO GROUND
- ▨ PANELBOARD - 151 TO 600 VOLTS TO GROUND
- ▨ DISTRIBUTION PANEL - 151 TO 600 VOLTS TO GROUND
- ⊕ TRANSFORMER
- ⊕<sup>60/3</sup> UNFUSED DISCONNECT SWITCH - "60/3" INDICATES 60 AMPERE SWITCH RATING AND POLES
- ⊕<sup>60/3</sup> FUSED DISCONNECT SWITCH - "60/3" INDICATES 60 AMPERE SWITCH RATING AND POLES / "50" INDICATES 50 AMPERE FUSE
- ▽ DATA OUTLET - MOUNTING AT 18" A.F.F. PROVIDE (1) CAT6 CABLE IN 3/4" CONDUIT BACK TO SERVER ROOM.
- ⊕<sup>SL</sup> FIRE ALARM DUCT SMOKE DETECTOR
- TS/⊕<sup>FPS</sup> SPRINKLER SYSTEM TAMPER SWITCH/FLOW SWITCH
- ⊕<sup>HP</sup> FIRE ALARM HORN WITH VISUAL STROBE LIGHT AND WEATHERPROOF HOUSING - MOUNTED AT 80" A.F.F.
- ⊕<sup>SD</sup> FIRE ALARM SMOKE DETECTOR, CEILING MOUNTED
- ⊕<sup>FACP</sup> FIRE ALARM CONTROL PANEL
- ⊕<sup>PP</sup> MUSHROOM HEAD PUSHBUTTON OPERATOR - MOUNTING AT 48" A.F.F.
- ⊕<sup>CR</sup> ACCESS CONTROL SYSTEM CARD READER - SEE TYPICAL SECURE DOOR DETAIL FOR SECURE DOOR REQUIREMENTS
- ⊕<sup>CC</sup> CLOSED CIRCUIT TELEVISION CAMERA FURNISHED BY LAKELAND CC - MOUNTING AT 80" A.F.F. PROVIDE 3/4" CONDUIT WITH CAT6 CABLE FROM SERVER ROOM TO LOCATIONS INDICATED.
- ⊕<sup>CC</sup> CLOSED CIRCUIT TELEVISION CAMERA FURNISHED BY LAKELAND CC - CEILING MOUNTED. PROVIDE 3/4" CONDUIT WITH CAT6 CABLE FROM SERVER ROOM TO LOCATIONS INDICATED.
- ⊕<sup>W</sup> WIRELESS ACCESS POINT PROVIDED BY LAKETRAN - PROVIDE (2) TWO CAT6 CABLES WITH 15' SERVICE LOOPS FROM SERVER ROOM TO LOCATION INDICATED.
- ⊕<sup>PN</sup> PLAN NOTE TAG, REFER TO PLANS FOR DESCRIPTION
- ⊕<sup>AH-3</sup> INDICATES POWER CONNECTION TO AIR HANDLER #3-REFER TO EQUIPMENT CONNECTION SCHEDULES FOR REQUIREMENTS
- A.F.F. ABOVE FINISHED FLOOR
- WP WEATHERPROOF
- U.O.N. UNLESS OTHERWISE NOTED
- ⊕<sup>60/3</sup> ONE-LINE DIAGRAM REPRESENTATION OF A MOLDED CASE CIRCUIT BREAKER - "60/3" INDICATES 60 AMPERE CIRCUIT BREAKER RATING AND POLES
- ⊕<sup>T</sup> ONE-LINE DIAGRAM REPRESENTATION OF A TRANSFORMER, SIZE AS NOTED
- ⊕<sup>M</sup> ONE-LINE DIAGRAM REPRESENTATION OF A METER

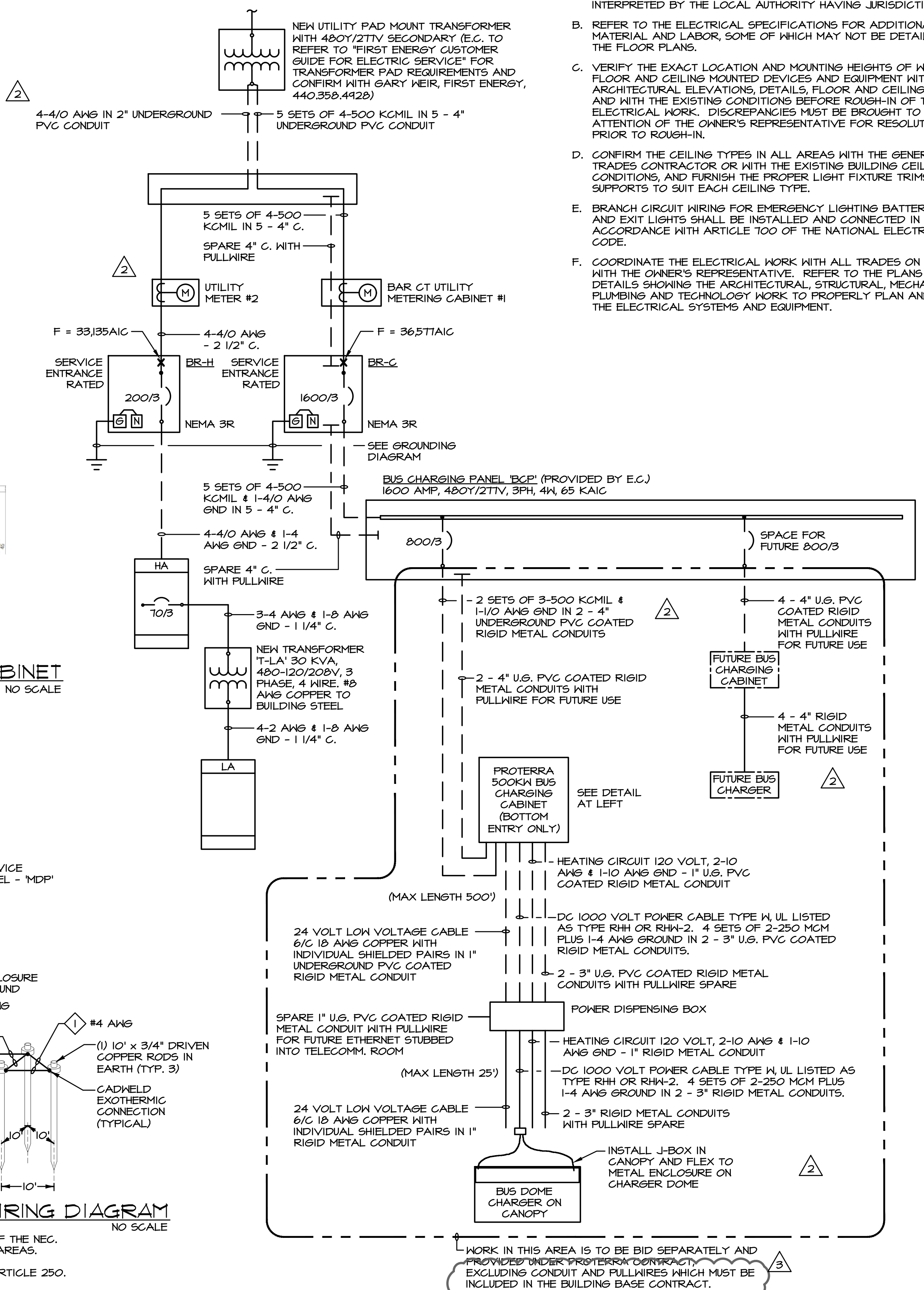

ONE LINE DIAGRAM  
NO SCALE

WORK IN THIS AREA IS TO BE BID SEPARATELY AND PROVIDED UNDER PROTERRA CONTRACT, EXCLUDING CONDUIT AND FILLWIRES WHICH MUST BE INCLUDED IN THE BUILDING BASE CONTRACT.

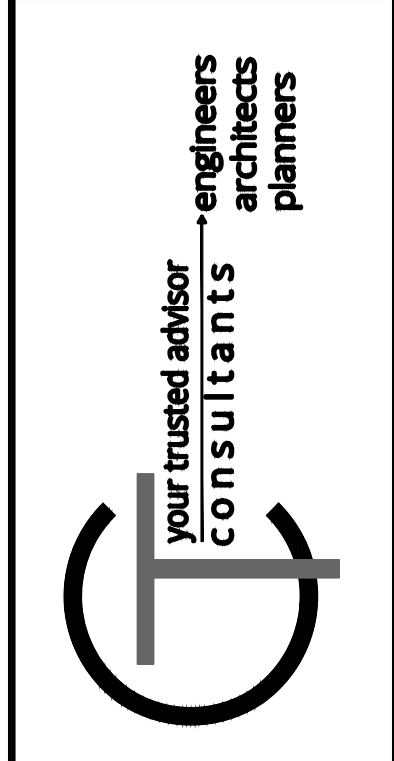
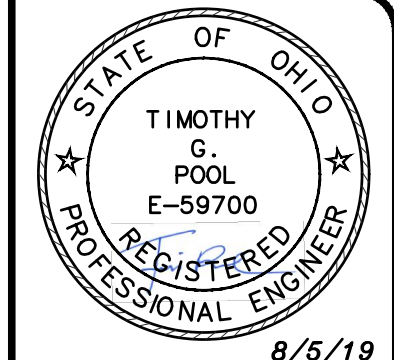

DATE	REVISION	NO	CD	ISSUED FOR:	ISSUE DATE:	SCALE:	DESIGNED BY:	DRAWN BY:	CHECKED BY:
8/05/2019		1			08/05/2019	AS SHOWN	BMS	BMS	TOP
8/23/2019		2							
8/30/2019		3							

LAKELAND TRANSFER STATION  
LAKELAND COMMUNITY COLLEGE  
7700 CLOCKTOWER DR., KIRTLAND, OH 44094

**ELECTRICAL SYMBOLS, NOTES AND DIAGRAMS**

PROJECT NO.	18050002
DISCIPLINE	ELECTRICAL
SHEET NAME	E-1
SHEET	OF

